

Simulation of Solar Powered DC Motor Control Using H-Bridge Converter

Dakaju Sai Durga Manasa¹, Alla Raghu Ram², Mergu Chandramouly³

¹PG Scholar, JNTUH College Of Engineering Hyderabad (Autonomous) Hyderabad, Telangana, India.

dakojusaidurgamnasa@gmail.com

²Professor, JNTUH College Of Engineering Hyderabad (Autonomous) Hyderabad, Telangana, India.

³Research Scholar, JNTUH College Of Engineering Hyderabad (Autonomous) Hyderabad, Telangana, India

Received Date : March 3, 2022 Accepted Date : March 23, 2022 Published Date : April 07, 2022

ABSTRACT

In this paper, the solar powered DC motor control system is considered and simulations are performed using various controllers and H-Bridge Buck Boost converter. The parameters varied are: irradiance and temperature. When input parameters are changed abruptly, such as sudden rise or fall in temperature or irradiance, DC motor performance is observed. These parameters are changed separately, keeping other parameter constant. The main aim is to obtain smooth DC motor control and operation under all input conditions. The simulations results are executed and compared for different controllers using MATLAB/SIMULINK environment.

Key words: PV array, Buck-Boost Converter, H-Bridge Converter, Differential Controller, PI controller, PID Controller, PMDC Motor control.

1. INTRODUCTION

The biggest threat to modern life is the energy crisis. Causes for energy shortages are over consumption, increase in population, poor infrastructure, untested renewable energy options, and various other factors. Fossil fuels provide a large portion of the world's present-day energy demand. But, fossil fuels such as petroleum, coal, gas are expensive besides detrimental to the environment, and energy supplies are limited. Climate change, economic stagnation, environmental degradation, and health of public are all consequences of mineral emissions. Solar energy is undoubtedly used widely among other energy sources.[1] It is limitless, clean, economical, commendable, stable, environmentally friendly, reliable, and in need of minimal maintenance, opens the door to independence of energy supply.

The basic electrical motor is DC Motor which has many applications in daily life. It is needed to control the DC motor powered from solar energy for smooth operation. The H-bridge Buck-Boost converter is considered to be efficient compared with others and high stability is provided while maintaining high efficiency of conversion.[2]

The Buck part was performed to obtain an acceptable stability and the Boost section was performed to obtain an improved transient performance.

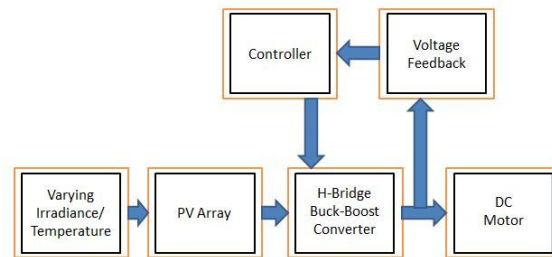

Figure 1: Block diagram of DC Motor with solar power supply

In the above block diagram, DC motor is fed by solar power with H-Bridge Buck- Boost converter. Inputs to PV array are Varying Irradiance and Temperature. PV Array is connected to H-Bridge Converter. Output of H-Bridge Buck-Boost Converter is connected to DC Motor[3]. Voltage feedback is connected from the H-Bridge Converter's output to the controller's input. Pulses are generated by the Controller to control the H-Bridge Converter's switching.

For any sudden changes in temperature rise or irradiance falls, motor input effects. H-Bridge Buck-Boost converter supplies constant input to DC motor.

2. ANALYSIS OF SUBSYSTEMS

The proposed system of the thesis is solar powered DC motor. Various blocks present in the system are varying irradiance/temperature, PV array, controller, DC motor, H-Bridge Buck-Boost converter, and voltage feedback. The block diagram of system is given in Figure 1.

The block diagram shows connections between various blocks of system. Power flows from PV array to H-Bridge converter then to DC motor. Variable input values of solar PV are Irradiance and temperature

2.1 Varying Irradiance/Temperature

The variable input parameters are; irradiance & temperature are applied to PV Array[4]. For variable irradiance and constant temperature, a step signal quantity is used to show the change in irradiance and a constant temperature is applied. Irradiance is varied from 600 W/m² to 1000 W/m². And temperature is kept constant at 35°C. In case of constant irradiance and variable temperature, a constant Irradiance quantity is represented by using a constant block. The step signal shows sudden changes in temperature. Irradiance is maintained at a constant value of 1000 W/m² and step change in temperature is from 25°C to 45°C.

2.2 PV Array

PV module used here is 1Soltech 1STH-350-WH. Here 28 strings connected in parallel and 1 string series connected module.

Module data:

- Maximum Power = 349.59 W
- Cells per module (Ncell) = 80
- Open circuit voltage $V_{oc} = 51.5$ V
- Short-circuit current $I_{sc} = 9.4$ A
- Voltage at maximum power $V_{mp} = 43$ V
- Current at maximum power I_{mp} (A) = 8.13
- Temperature coefficient of V_{oc} (%/°C) = -0.36
- Temperature coefficient of I_{sc} (%/°C) = 0.09

Model parameters:

- Light-generated current $I_L = 9.447$ A
- Diode Saturation current $I_0 = 3.2328e-10$ A
- Diode ideality factor = 1.045
- Shunt resistance $R_{sh} = 47.9694$ ohms
- Series resistance $R_s = 0.22$ ohms

2.3 H- Bridge Buck-Boost Converter

The H-bridge converter is used for controlling the speed and direction of a DC motor. Four switches are there in all. When S3 and S4 are open and switches S1 and S2 are closed, a positive voltage is applied across the motor. Similarly, for switches S3 and S4 are in closed condition, S1 and S2 are in open condition results in reversing the voltage and to run the motor in reverse direction.

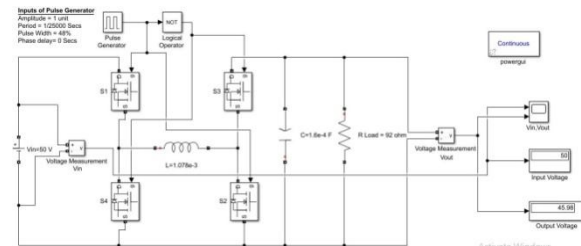

Figure 2: Simulation Diagram of H-Bridge Converter

The H-bridge Buck-Boost Converter is designed for input voltage of 50 V and output voltage of 46 V.

Parameters of Pulse generator:

- Amplitude = 1 unit
- Period = 1/25000 sec
- Pulse width = 48%
- Phase delay = 0 sec

Parameters of H-Bridge converter:

- L = 1.0678e-3 H
- C = 1.6e-4 F
- R = 92 Ω

2.3 Controller Design

Solar irradiation is not constant source, it is fluctuating in nature. For large variations in solar irradiance, DC motor operation is affected. This effect can be reduced by designing a suitable controller to get the desired operation of DC Motor. The motor effects can be reduced by using controller to get desired the output of DC Motor irrespective of fluctuations in input. This can be used to get the desired output voltage values. [5]

i. Differential controller

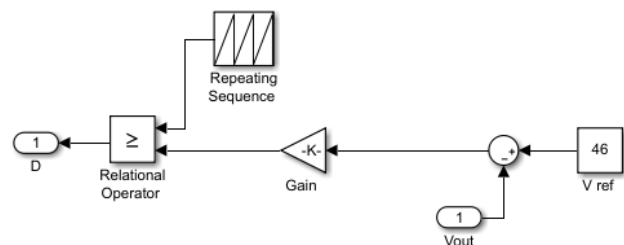

Figure 3: Differential Controller Subsystem

Block parameters of repeating sequence:

Time values: [0 1]*[1/25000]

Output values: [0 2]

Value of gain, $k = 1/46$

Reference voltage, $V_{ref} = 46 \text{ V}$

ii. PI controller

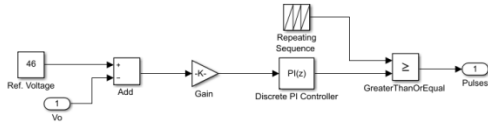

Figure 4: PI Controller Subsystem

Block parameters of repeating sequence:

Time values: [0 1]*[1/25000]

Output values: [0 2]

Value of gain, $k = 1/46$

Reference voltage, $V_{ref} = 46 \text{ V}$

$K_p = 0.5, K_i = 0.5$

iii. PID Controller

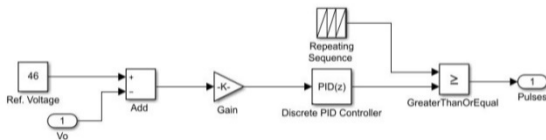

Figure 5: PID Controller subsystem

Block parameters of repeating sequence:

Time values: [0 1]*[1/25000]

Output values: [0 2]

Value of gain, $k = 1/46$

Reference voltage, $V_{ref} = 46 \text{ V}$

Block parameters of Discrete PID Controller:

$K_p = 0.1$

$K_i = 0.1$

$K_d = 0.001$

2.4 DC Motor

The permanent magnet DC motor is considered as a load that is used to view the effect of various input parameters. Simulation block and the output values are shown below.[6][7]

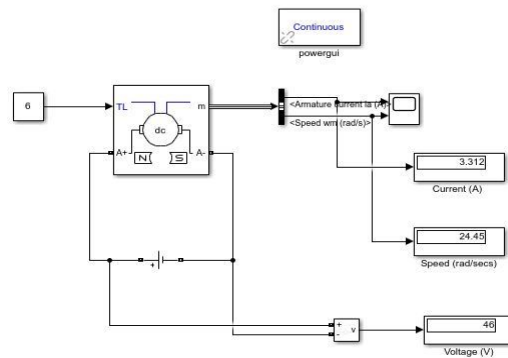

Figure 6: Simulation Diagram of DC Motor

DC Motor Specifications:

Armature resistance, $R_a = 0.6 \Omega$

Armature inductance, $L_a = 0.012 \text{ H}$

Torque constant = 1.8 N-m/A

Total inertia $J = 1 \text{ kg.m}^2$

Initial speed = 1 rad/sec

Load torque, $T_L = 6 \text{ N-m}$

2.5 Voltage Feedback

Voltage measurement block measures the voltage at the load and is given as feedback to controller making it operate in closed loop condition. Controller produces gating pulses for converter. This results in obtaining stable output voltage and speed.

3. PROPOSED SYSTEM

The proposed system presented here comprises various blocks like PV array; H-Bridge Buck Boost Converter, PMDC Motor, Controller, Reference voltage as in as given in Figure7. The output voltage of converter is given as inputs to the controller. This proposed model eliminates additional control unit for DC Motor. H-Bridge configuration gives constant input to the DC Motor. Changes in input fluctuations are controlled by H-Bridge with PID controller. For any climate changes like irradiance and temperature, the DC Motor smooth operation is achieved by this proposed model.

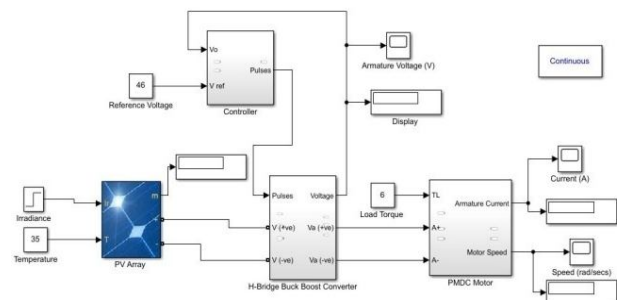

Figure 7: Simulink Diagram of DC Motor with solar input

The temperature & Irradiance are given as inputs to PV array. Output of solar PV Array is connected to input of H-Bridge converter. Output of H-Bridge converter is given to input of DC motor. H-bridge Buck Boost converter is given in Figure 2. PMDC Motor subsystem is presented in Figure 6. For open loop operation of DC motor, controller is not connected. Instead, pulse generator given in Figure 2 is used to give pulses to converter. For closed loop control of DC motor, pulse generator is removed and controller circuit is connected. Controller generates pulse signals for switching of H-Bridge converter. To examine the output results, the controller subsystem, as illustrated in Figure 7, comprises of differential, PI or PID controllers. Differential controller is given in Figure 3. PI controller is given in Figure 4. PID Controller is given in Figure 5.

4. SIMULATION RESULTS

The proposed simulation model is tested for various input fluctuations. The DC motor behavior and the H bridge converter output voltage are observed.[8]

4.1 DC Motor without Controller & Variable Irradiance

Here, converter switches are controlled using pulses generated by pulse generator. DC motor armature current, armature voltage and speed are observed.

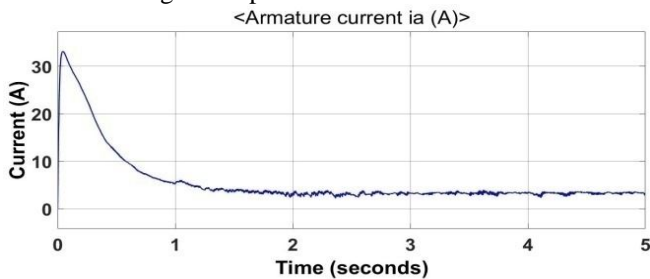

Figure 8: Armature Current of DC Motor when manually controlled

DC Motor operates without any controller, in this case, for any changes in irradiance the speed and motor armature current will affect. From above figure 8 current waveform, output current initially increases, then falls and settles at 3.228 A.

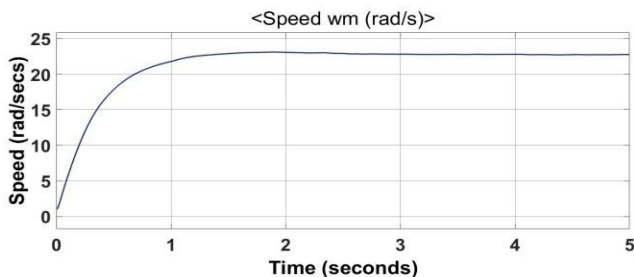

Figure 9: Speed of DC Motor when manually controlled

As the irradiance increases, speed of motor also increases. From the Figure 9, it is shown that Initial speed of motor is 1 rad/sec. Speed increases and finally settles at 22.73 rad/sec.

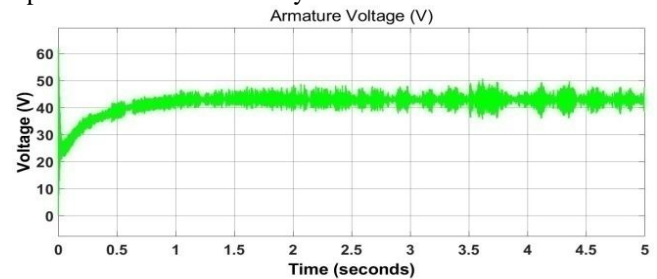

Figure 10: Armature Voltage of DC Motor when manually controlled

The above H-Bridge output voltage waveform is having fluctuations. Figure 10 shows the H-Bridge converter output voltage curves. This curve contains fluctuations in magnitude due to sudden rise in irradiance. Output voltage increases and finally varies between (42-48) V.

4.2 DC Motor with Differential Controller & Variable Irradiance

Here, converter switches are controlled using pulses generated by Differential controller. DC motor armature current, armature voltage and speed are observed.

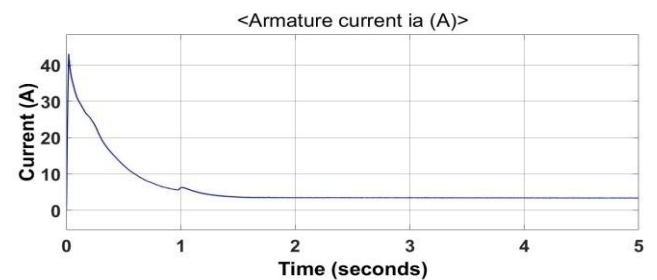

Figure 11: Armature Current of DC Motor using Differential Controller

DC Motor operates with differential controller, in this case, for any changes in irradiance the speed and motor armature current affects. From above Figure 11 current waveform, output current initially increases, then falls and settles at 3.398A.

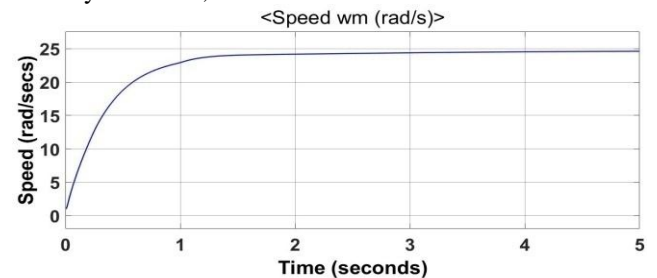

Figure 12: DC Motor Speed using Differential Controller

As the irradiance increases speed of motor also increases. From the Figure 12, it is shown that initial speed of motor is 1 rad/sec. Speed increases and finally settles at 24.53 rad/sec.

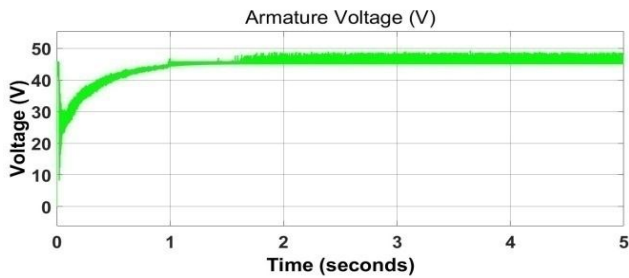

Figure 13: Armature Voltage of DC Motor using Differential Controller

H-Bridge output voltage waveform is having some fluctuations. Figure 13 shows the H-Bridge converter output voltage waveform. This curve is having fluctuations in magnitude due to sudden rise in irradiance. Output voltage increases and finally varies between (45-48) V.

4.3 DC Motor with PI Controller & Variable Irradiance

Here, converter switches are controlled using pulses generated by PI controller. DC motor armature current, armature voltage and speed are observed.

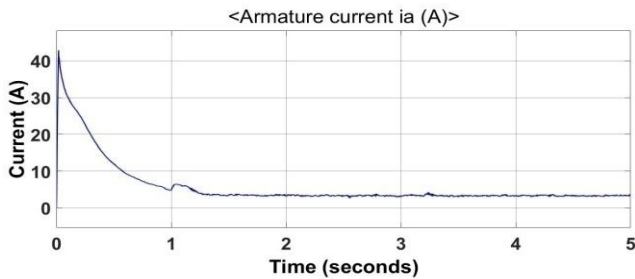

Figure 14: Armature Current of DC Motor using PI Controller

DC Motor operates with PI controller, in this case, for any changes in irradiance the speed and motor armature current values affects. From above Figure14, current waveform, output current initially increases then settles at 3.29 A.

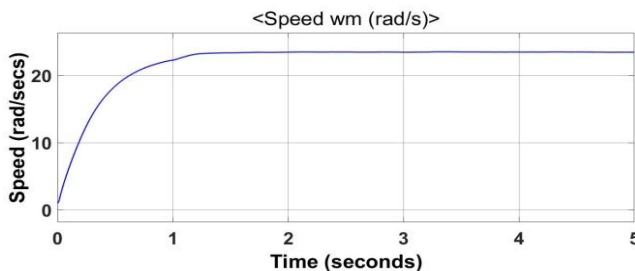

Figure 15: Speed of DC Motor using PI Controller

As the irradiance increases speed of motor also increases. From the Figure 15, it is shown that initial speed of motor is 1 rad/sec. Speed increases and finally settles at 23.4 rad/sec.

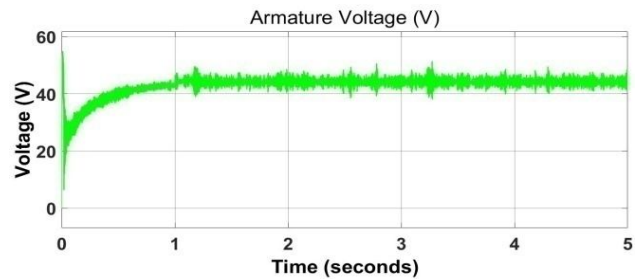

Figure 16: Armature Voltage of DC Motor with PI Controller

The output voltage waveform of H-Bridge is having fluctuations. Figure 16 shows the H-Bridge converter output voltage waveform. This curve is having fluctuations in magnitude due to sudden rise in irradiance. Output voltage initially increases and finally varies between (42-47) V.

4.4 DC Motor with PID Controller & Variable Irradiance

Here, converter switches are controlled using pulses generated by PID controller. DC motor armature current, armature voltage and speed are observed.

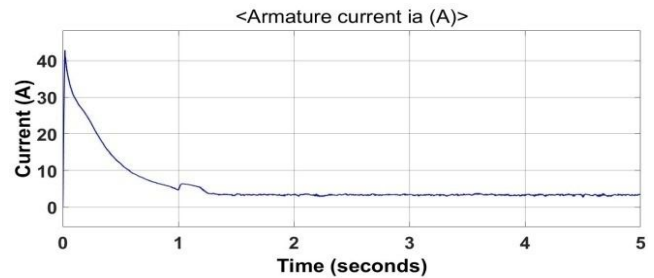

Figure 17: Armature Current of DC Motor with PID Controller
DC Motor operates with PID controller, in this case, for any changes in irradiance the speed and motor armature current parameters affects. From above Figure17 current waveform, output current initially increases, then falls and settles at 3.473A.

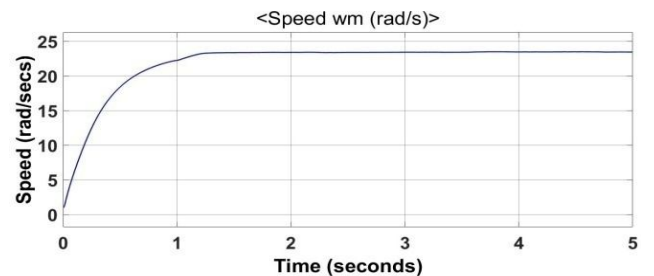

Figure 18: Speed of DC Motor using PID Controller

As the irradiance increases speed of motor also increases. From the Figure 15, it is shown that initial speed of motor is 1 rad/sec. Speed increases and finally settles at 23.47rad/sec.

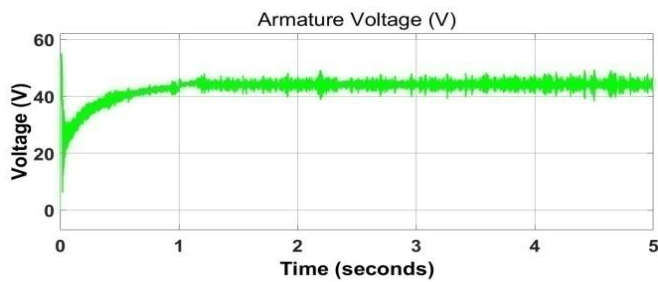

Figure 19: Armature Voltage of DC Motor with PID Controller.

Output voltage waveform of H-Bridge is having fluctuations. Figure 19 shows the H-Bridge converter output voltage waveform. This curve is having fluctuations in magnitude due to sudden rise in irradiance. Output voltage initially increases and finally varies between (43-46) V.

4.5 DC Motor without controller & Variable Temperature

Here, converter switches are controlled using pulses generated by pulse generator. DC motor armature current, armature voltage and speed are observed.

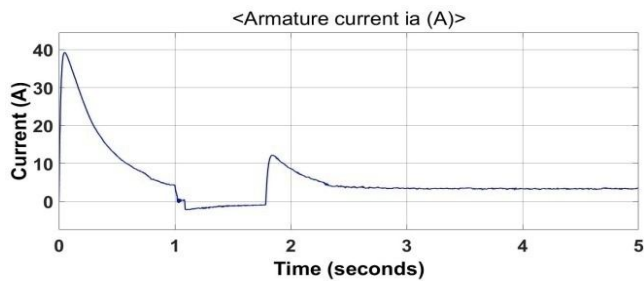

Figure 20: Armature Current of DC Motor when manually controlled

DC Motor operates without any controller, in this case, for any changes in temperature the speed and the motor armature current affects. From above Figure 20 current waveform, output current initially increases, then falls and settles at 3.375 A.

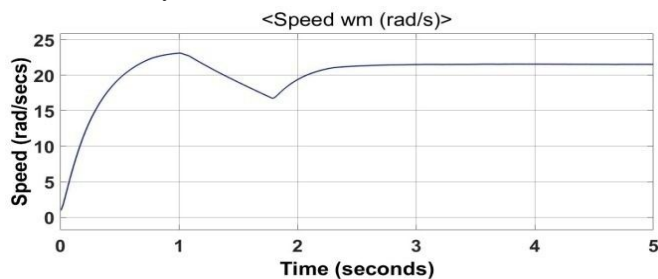

Figure 21: Speed of DC Motor when manually controlled

As the temperature increases, speed of motor decreases. From the Figure 21, it is shown that initial speed of motor is 1 rad/sec. Speed increases, then falls and settles at 21.75 rad/sec.

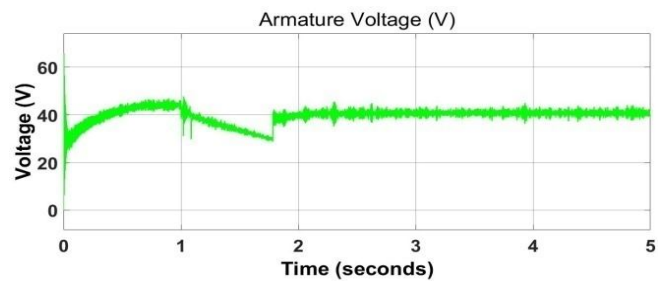

Figure 22: Armature Voltage of DC Motor when manually controlled

The output voltage of H-Bridge is having fluctuations. Figure 22 shows the H-Bridge converter output voltage waveform. This curve is having fluctuations in magnitude due to sudden rise in temperature. Output voltage initially increases and then falls and varies between (40-44) V.

4.6 DC Motor with Differential Controller & Variable Temperature

Here, converter switches are controlled using pulses generated by Differential controller. DC motor armature current, armature voltage and speed are observed.

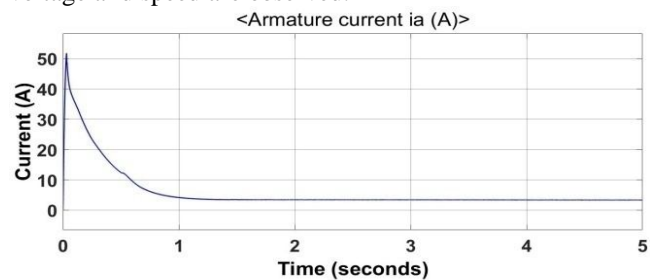

Figure 23: Armature Current of DC Motor using Differential Controller

DC Motor operates with differential controller, in this case, for any changes in temperature, the speed and the motor armature current affects. From above Figure 23 current waveform, output current initially increases, then falls and settles at 2.2 A.

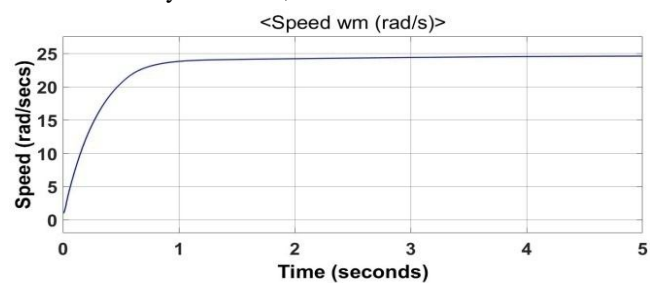

Figure 24: Speed of DC Motor using Differential Controller

As the temperature increases, speed of motor decreases. From the Figure 21, it is shown that initial speed of motor is 1 rad/sec. Speed initially increases, then falls and settles at 24.59 rad/sec.

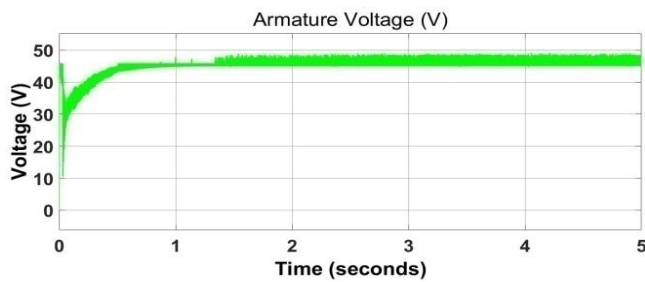

Figure 25: Armature Voltage of DC Motor using Differential Controller

The voltage waveform of H-Bridge is having fluctuations. Figure 25 shows the H-Bridge converter output voltage waveform. This curve is having fluctuations in magnitude due to sudden rise in temperature. Output voltage initially increases, then falls and finally varies between(45-48) V.

4.7 DC Motor with PI Controller & Variable Temperature

Here, converter switches are controlled using pulses generated by PI controller. DC motor armature current, armature voltage and speed are observed.

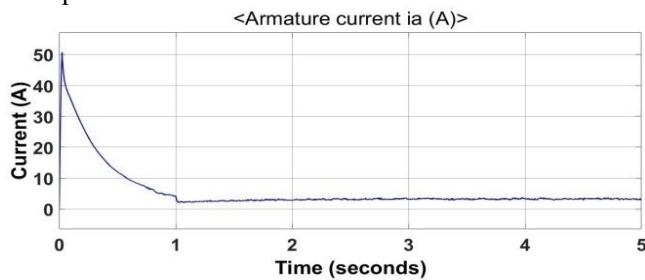

Figure 26: Armature Current of DC Motor with PI Controller

DC Motor operates with PI controller, in this case, for any changes in temperature, the speed and motor armature current affects. From above Figure 26, current waveform output current initially increases, then falls and settles at 3.3 A.

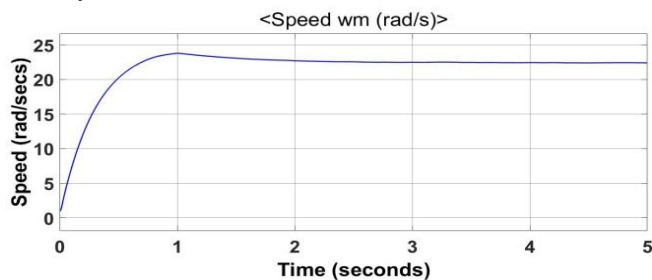

Figure 27: Speed of DC Motor using PI Controller

As the temperature increases, speed of motor decreases. From the Figure 27, it is shown that initial speed of motor is 1 rad/sec. Speed of motor initially increases, then falls and settles at 22.44 rad/sec.

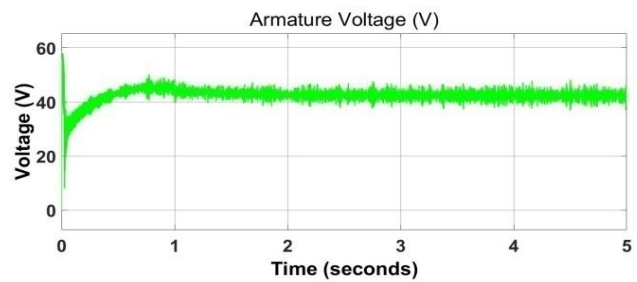

Figure 28: Armature Voltage of DC Motor using PI Controller

The voltage waveform of H-Bridge is having few fluctuations. Figure 28 shows the H-Bridge converter output voltage waveform. This curve is having fluctuations in magnitude due to sudden rise in temperature. Output voltage increases initially, then falls and varies between(40-47) V.

4.8 DC Motor with PID Controller & Variable Temperature

Here, converter switches are controlled using pulses generated by PID controller. DC motor armature current, armature voltage and speed are observed.

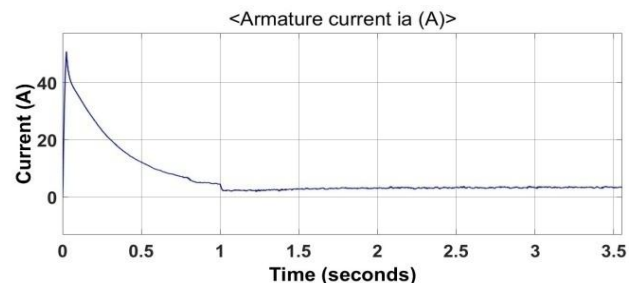

Figure 29: Armature Current of DC Motor using PID Controller

DC Motor operates with PID controller, in this case, for any changes in temperature, the speed and DC motor armature current affects. From above Figure 29 current waveform, output current initially increases, then falls and settles at 2.303A.

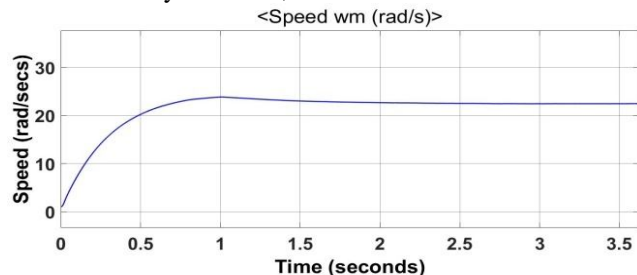

Figure 30: Speed of DC Motor using PID Controller

As the temperature increases, speed of motor decreases. From the Figure 30, it is shown that initial speed of motor is 1 rad/sec. Speed increases, then falls and settles at 23.65 rad/sec.

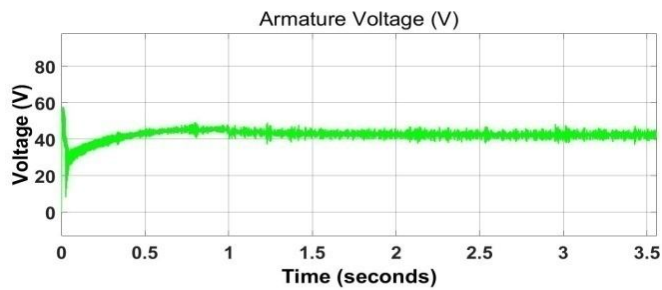

Figure 31: Armature Voltage of DC Motor using PID Controller

The waveform of H-Bridge is having fluctuations. Figure 31 shows H-Bridge converter output voltage waveform. This waveform is having fluctuations in magnitude due to sudden rise in temperature. Output voltage initially increases, then falls and varies between (40-43) V.

5. COMPARISON OF SIMULATION ESULTS

Solar power based DC Motor system is simulated and compared with various controllers[8]. This comparison done among Differential, PI and PID controllers embedded with H-bridge converter. It is observed that, among all the different types of controllers PID controller gives the better output results.[5] This controller performance is obtained for different type of input fluctuations. The solar irradiance and temperature are not constant in nature. The sudden change in climate creates the change in input quantities to the solar powered DC motor. This input change of irradiation and temperature are minimized with PID controlled H-Bridge converter connected to the DC motor.[9]

Table-1: Shows the comparison of DC motor parameters like armature voltage, current and the motor speed.

Table1: Comparative Analysis of Output Results

Controller		Without Controller	Differential Controller	PI Controller	PID Controller
Variable Irradiance (W/m ²)	Va (V)	42-48	45-48	42-47	43-46
	Ia (A)	3.228	3.398	3.29	3.473
	Speed (rad/s)	22.73	24.53	23.4	23.47
Variable Temperature (°C)	Va (V)	40-44	45-48	40-47	40-43
	Ia (A)	3.375	2.242	3.301	2.303
	Speed (rad/s)	22.73	24.59	22.44	23.65

6. CONCLUSIONS

This paper presents the modeling and simulation of solar power based DC motor controlled by H-Bridge Converter. The DC Motor output is maintained stable and fluctuations are minimized by connecting different controllers. In this, PID controller gives better performance than other controllers. This method is suitable in different field of applications to minimize the foreign oil usage and other energy resources. This approach focuses on maintaining a continuous power supply for the system and can generate higher output voltage than the supply voltage. The proposed system will provide financial and technical advantages than other alternative methods.[10]

REFERENCES

- [1] T. Anuradha, P. D. Sundari, S. Padmanaban, P. Siano, and Z. Leonowicz, “Comparative analysis of common MPPT techniques for solar PV system with soft switched, interleaved isolated converter,” *Conf. Proc. - 2017 17th IEEE Int. Conf. Environ. Electr. Eng. 2017 1st IEEE Ind. Commer. Power Syst. Eur. IEEEIC / I CPS Eur. 2017*, no. November, 2017, doi: 10.1109/IEEEIC.2017.7977885.
- [2] P. Hridya and P. Saritha, “High gain single stage inverter,” *2017 Int. Conf. Intell. Comput. Instrum. Control Technol. ICICICT 2017*, vol. 2018-Janua, pp. 387–392, 2018, doi: 10.1109/ICICICT1.2017.8342595.
- [3] T. Dineshkumar, P. Thirumoorthi, and S. Rajalakshmi, “Design of boost inverter for solar power based stand alone systems,” *Int. J. Eng. Adv. Technol.*, vol. 8, no. 6 Special issue, pp. 125–129, 2019, doi: 10.35940/ijeat.F1026.0886S19.
- [4] K. Dubey and M. T. Shah, “Design and simulation of Solar PV system,” *Int. Conf. Autom. Control Dyn. Optim. Tech. ICACDOT 2016*, pp. 568–573, 2017, doi: 10.1109/ICACDOT.2016.7877649.
- [5] A. B. Smitha, S. C. N. Shetty, and B. Baby, “PID Controller Tuning and Its Case Study,” *Int. J. Res. Appl. Sci. Eng. Technol.*, vol. 4, no. Vi, pp. 292–299, 2016.
- [6] M. N. M. Haque, M. Naeem-Ur-Rahman, S. C. Sarkar, M. S. Miah, I. Ahammad, and M. A. Islam, “Design and simulation of a forcible buck-boost controlling solar powered DC motor,” *IEEE Int. Conf. Power, Control. Signals Instrum. Eng. ICPCSI 2017*, pp. 131–136, 2018, doi: 10.1109/ICPCSI.2017.8391958.
- [7] N. Urasaki, T. Senjyu, K. Uezato, and T. Funabashi, “Adaptive dead-time compensation strategy for permanent magnet synchronous motor drive,” *IEEE Trans. Energy Convers.*, vol. 22, no. 2, pp. 271–280, 2007, doi: 10.1109/TEC.2006.875469.

- [8] S. Jayaprakash and V. Ramakrishnan, "Simulation of solar based DC-DC converter for armature voltage controlled separately excited motor," *2014 Int. Conf. Adv. Electr. Eng. ICAEE 2014*, 2014, doi: 10.1109/ICAEE.2014.6838539.
- [9] S. Das, M. M. Rashid, J. Firdous, and M. N. M. Haque, "Design, Analysis and Simulation of a Solar Powered DC Motor using MOSFET H-bridge Converter," *2020 11th Int. Conf. Comput. Commun. Netw. Technol. ICCCNT 2020*, 2020, doi: 10.1109/ICCCNT49239.2020.9225583.
- [10] L. Mitra and N. Swain, "Closed loop control of solar powered boost converter with PID controller," *2014 IEEE Int. Conf. Power Electron. Drives Energy Syst. PEDES 2014*, 2014, doi: 10.1109/PEDES.2014.7041973.