

A Novel on Development and Implementation of a Simplified Self-Tuned Neuro–Fuzzy-Based IM Drive

G.yuva kishore¹, K.Guna prasad²

PG Student [PE&ED], Dept. of EEE, SISTK, ykishore494@gmail.com, India¹

Assistant professor, Dept. of EEE, SISTK, gunaprasad.mtech@gmail.com, Andhra Pradesh, India²

Abstract— A novel simplified self-tuned neuro–fuzzy controller (NFC) for speed control of an induction motor (IM) drive is presented in this paper. The proposed NFC amalgamates fuzzy logic and a four-layer neural network structure. Only speed error is employed as input to the NFC so that the computational encumbrance of the NFC is reduced and it becomes congruous for authentic-time industrial drive applications. Predicated on the erudition of back-propagation algorithm, an unsupervised self-tuning method is developed to adjust membership functions and weights of the proposed NFC so that the performance will be kindred to that of the conventional two-input NFC. The consummate drive incorporating the proposed self-tuned NFC is experimentally implemented utilizing a digital signal-processor board DS-1104 for a laboratory 1/3-hp motor .The efficacy of the proposed NFC-predicated vector control of IM drive is tested in both simulation and experiment at different operating conditions. Comparative results show that the simplification of the proposed NFC does not decrement the system performance as compared to the conventional NFC. In order to prove the preponderating of the proposed simplified NFC, the performances of the proposed NFC are additionally compared to those obtained by a conventional proportional–integral controller.

Key words—Back propagation (BP), digital signal processor(DSP), indirect field-oriented control (FOC), induction motor(IM), neuro–fuzzy control, real-time implementation, self-tuning.

I. INTRODUCTION

INDUCTION motors (IMs) have been widely utilized as work horse in the industry over the years due to its low cost ,and simple and robust construction. However, the control of IM is involute

due to its nonlinear nature, and the parameters change with operating conditions. Traditionally, the conventional fine-tuned-gain proportional–integral (PI) and PI–derivative(PID) controllers and their adaptive versions have been widely utilized for motor drives. However, the fine-tuned-gain and adaptive controllers often suffer from chattering in the steady state ,parameter variations, and load perturbances [1]–[5]. Over the last two decades, researchers have been working to apply keenly intellective algorithms for motor drives due to some of their advantages as compared to the conventional PI, PID controllers and their adaptive versions [11]–[17]. The main advantages are that the designs of these controllers do not depend on precise system mathematical model and their performances are robust .In this paper, a neuro–fuzzy controller (NFC) is considered because of the inhibitions of both fuzzy logic control (FLC) and artificial neural network (ANN) controllers. A fuzzy controller utilized for speed control of motor drive has asymmetric membership functions which need much more manual adjusting by tribulation and error if optimized performance is wanted [1], [8]. On the other hand, it is profoundly tough to engender a serial of training data for ANN that can handle all the operating modes [15],[19]. The NFCs, which overcome the disadvantages of FLC and ANN controllers, have been utilized by authors and other researchers for motor drive applications [11]–[17]. Despite many advantages of astute controllers, the industry has been still reluctant to apply these controllers for commercial drives due to high computational burden imposed by sizably voluminous number of membership functions, weights, and rules, particularly on self tuning condition [20], [21]. High computational burden leads to low sampling frequency, which is not sufficient for authentic-time implementation. In [13],

only weights were tuned online, but the membership functions were fine-tuned to keep the computational burden at plausible level. The membership functions we readjusted in simulation by tribulation-and-error procedure. Moreover ,a high-torque ripple was observed due to the low sample rate for the conventional two-input NFC. An expeditious processor may be habituated to implement such high computational perspicacious algorithms ,but the high cost of the expeditious processor is another concern for the industry .Conventional NFCs conventionally utilize two inputs $\Delta\omega$ and ω' (speed error and expedition, respectively), which lead to an immensely colossal number of membership functions and rules. The adoption of ω' can ameliorate the controller's robustness [23]–[25]. However ,the arduousness of quantifying expeditious and precise expedition[24], [26] deteriorates this ability and even makes utilization of expedition useless. Therefore, in order to reduce the computational burden, a simplified NFC with one input, three membership functions, and a four-layer structure is proposed in this paper. A supervised self-tuning method is developed predicated on the erudition of back-propagation (BP) algorithms

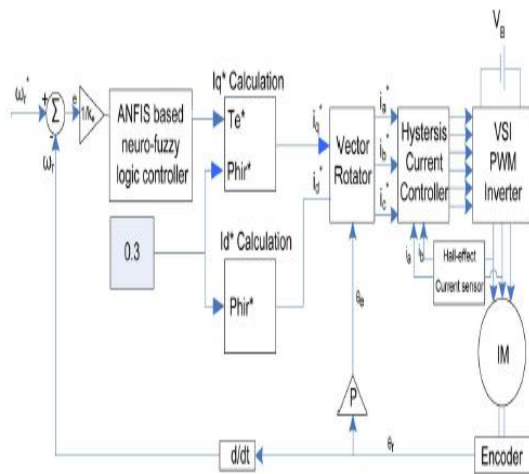

Fig. 1. Block diagram of the proposed simplified NFC-based IM drive.

adjust the parameters of the membership functions and weights in order to minimize the square of the speed error between genuine and reference values .The performance of the proposed simplified NFC-

predicated IM drive is tested in both simulation and experiment. It is found that the proposed NFC does not decrement the system performance as compared to the conventional NFC. Moreover, the proposed NFC is found superior to the conventional PI controller.

II. MOTOR DYNAMICS AND CONTROL STRUCTURE

A. IM Dynamics

The mathematical model of a three-phase Y-connected squirrel-cage IM in a de–qe synchronously rotating reference frame is described in (1)–(4), shown at the bottom of the page ,where veds and veqs are the d, q-axis stator voltages, ieds and ieqs are the d, q-axis stator currents, iedr and ieqr are the d, q-axis rotor currents, Rs and Rr are the stator and rotor resistances per phase, and Ls and Lr are the self-inductances of the stator and rotor, respectively; Lm is the mutual or magnetizing inductance; ωe is the speed of the rotating magnetic field; ωr isthe rotor speed; P is the number of poles; p is the differential operator (d/dt); Te is the developed electromagnetic torque ;TL is the load torque; Jm is the rotor inertia; Bm is the rotor damping coefficient; and θr is the rotor position. The motor parameters are given in the Appendix.

$$T_e = J_m + \frac{dw_r}{dt} + B_m w_r + T_L \quad (1)$$

$$T_e = \frac{3p}{2} L_m (i_{qs}^e i_{dr}^e - i_{ds}^e i_{qr}^e) \quad (2)$$

$$\frac{d\theta}{dt} = w_r \quad (3)$$

B. Control Structure

The key feature of the field-oriented control (FOC) is to keep the magnetizing current at a constant rated value by setting $i_{eqr} = 0$. Thus, the torque-engendering current component i_{eqs} can be adjusted according to the torque demand. With this postulation, the mathematical formulations can be re-indited as

$$\omega_{sl} = \frac{R_r i_{qs}^e}{L_r i_{ds}^e} \quad (4)$$

$$i_{ds}^e = \frac{\delta_{dr}^e}{L_r} \quad (5)$$

$$T_e = \frac{3}{2} \frac{p}{L_r} \frac{L_m}{L_r} \delta_{dr}^e i_{qs}^e \quad (6)$$

where ω_{sl} is the slip speed and λ_{edr} is the d-axis rotor flux linkage. Equations (1)–(7) are habituated to simulate the whole drive system. The schematic diagram of the proposed NFC-predicated indirect FOC of IM is shown in Fig. 1. The rudimentary configuration of the drive system consists of an IM victualled by a current-controlled voltage source inverter (VSI). The normalized speed error $\Delta\omega\%$ is processed by the NFC to engender the reference torque T The command current $i_q(n)$ is calculated from (7) as follows:

$$i_q^*(n) = T_e^* \frac{2}{3} \frac{L_r}{L_m} \frac{1}{\delta_{dr}^*} \quad (7)$$

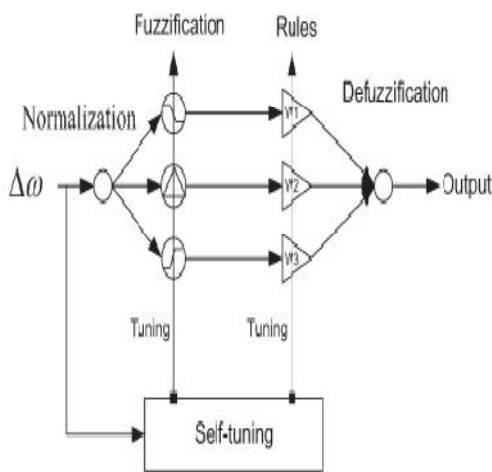

Fig 2: Structure of proposed NFC

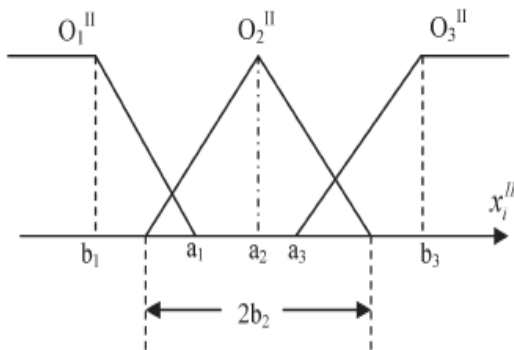

Fig. 3. Membership functions for input.

III. DESIGN OF SPECIFIC NFCS

A. Proposed NFC

The proposed NFC incorporates fuzzy logic and a cognition algorithm with a four-layer ANN structure, as depicted in

Fig. 2. The cognition algorithm modifies the NFC to proximately match the desired system performance. The detailed discussions on different layers of the NFC are given in the following. Input Layer: The input of the proposed NFC is the normalized speed error, which is given by

$$O^I = \frac{W^* - W}{W^*} * 100\% \quad (8)$$

where ω is the quantified speed, ω^* is the command speed, and I denotes the first layer .Fuzzification Layer: In order to get fuzzy number from input(x_i^{II}), three membership functions O_{I1} , O_{I2} , and O_{I3} are utilized, which are shown in Fig. 3. The three nodes in fuzzification layer of NFC shown in Fig. 2 represent these three membership functions. Here, O stands for output, superscript denotes the layer number, and subscripts denote the node numbers. The linear triangular and trapezoidal functions are culled as the membership functions so that the computational burden is low as compared to any exponential functions.

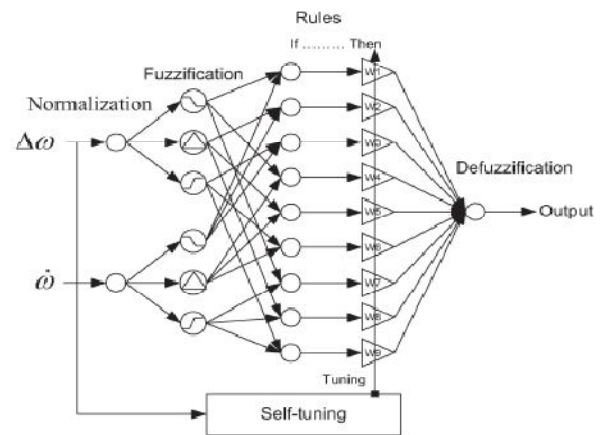

Fig. 4. Structure of a conventional NFC.

As per Fig. 3, the equations representing the three membership functions can be indited as follows: where x_i^{II} is the input of the second layer, which is the output of the first layer. It is considered that $a_2 = 0$ so that the membership functions become symmetrical and it wital further reduces the

computational burden. Thus, the membership functions O_{II1} , O_{II2} , and O_{II3} represent negative, zero, and positive speed errors, respectively.

Rule Layer: No “AND” logic is needed in the rule layer since there is only one input in the input layer. The node equations in the rule layer are designated as

$$O_i^{III} = x_i^{III} w_j = O_i^{II} w_j \quad (6)$$

where x_i^{III} is the input of the third layer, which is the same as the output of the second layer. *Defuzzification Layer:* The center-of-gravity method is used to determine the output of NFC. The node equation is specified as

$$Y_u = O_i^{VI} = \frac{\sum x_i^{vi}}{\sum o_i^{II}} = \frac{\sum o_i^{iii}}{\sum o_i^{II}} \quad (9)$$

where x_i^{VI} is the input of the fourth layer, which is same as the output of the third layer.

B. Conventional NFC

In order to compare the performance of the proposed simplified NFC, a conventional two-input NFC is withal designed, as shown in Fig. 4. The normalized speed error and its derivative are the two inputs to the conventional NFC. In order to make a fair comparison, the membership functions of conventional NFC are considered equipollent to those of the proposed NFC but with fine-tuned parameters. Kindred self-tuning methods are withal utilized for both NFCs.

IV. ONLINE SELF-TUNING ALGORITHM

Since it is impossible to determine or calculate the desired NFC output $ieqs$ and find training data offline covering all operating conditions, a kind of unsupervised online self-tuning method is developed predicated on BP algorithm [27]. In lieu of utilizing the desired controller output $ieqs$ as target, a reinforcement signal (r), which assesses the performance of the controller and evaluates the current state of the system, is employed to guide our control action into transmuting in the right direction as well as engender the desired replication. The task of NFC is to modify its parameters so that the objective function of the reinforcement signal is decremented.

The objective function to be minimized is defined by

$$E = \frac{1}{2} r^2 = \frac{1}{2} (w^* - w)^2 \quad (10)$$

Hence, the learning rules can be derived as follows:

$$a_i(n+1) = a_i(n) - n_a \frac{\partial E}{\partial a_i} \quad (11)$$

$$b_i(n+1) = b_i(n) - n_b \frac{\partial E}{\partial b_i} \quad (12)$$

$$c_i(n+1) = w(n) - n_c \frac{\partial E}{\partial w_i} \quad (13)$$

where η^{ai} , η^{bi} , and η^{wj} are the learning rates of the corresponding parameters. The derivatives can be found by chain rule as

$$\frac{\partial E}{\partial a_i} = \frac{\partial E}{\partial r} \frac{\partial r}{\partial \omega} \frac{\partial \omega}{\partial y_u} \frac{\partial y_u}{\partial o_i^{II}} \frac{\partial o_i^{II}}{\partial a_i} \quad (14)$$

$$\frac{\partial E}{\partial b_i} = \frac{\partial E}{\partial r} \frac{\partial r}{\partial \omega} \frac{\partial \omega}{\partial y_u} \frac{\partial y_u}{\partial o_i^{II}} \frac{\partial o_i^{II}}{\partial b_i} \quad (15)$$

$$\frac{\partial E}{\partial w_i} = \frac{\partial E}{\partial r} \frac{\partial r}{\partial \omega} \frac{\partial \omega}{\partial y_u} \frac{\partial y_u}{\partial o_i^{II}} \frac{\partial o_i^{II}}{\partial w_i} \quad (16)$$

Where common parts are

$$\frac{\partial E}{\partial r} = r = w^* - w \quad (17)$$

$$\frac{\partial r}{\partial w} = -1 \quad (18)$$

$$\frac{\partial y}{\partial y_u} = J(t) \quad (19)$$

From (10)–(24), the update rules can be determined as follows:

Predicated on the aforementioned update rules, the following steps are employed for tuning the parameters of a_1 , a_3 , b_1 , b_2 , b_3 , and w_j .

Step 1) First, an initial set of fuzzy logic rules and initial values of a_1 , a_3 , b_1 , b_2 , b_3 , and w_j are culled.

Step 2) The normalized speed error is calculated, which is input to the NFC.

Step 3) Fuzzy reasoning is performed for the input data. The membership values O_{III} are then calculated by utilizing (10)–(12).

Step 4) Tuning of the weights w_j of the consequent part is performed by utilizing (25).

Step 5) Tuning of $a_1, a_3, b_1, b_2,$ and b_3 is done by superseding the tuned authentic number w_j obtained in step 4), the quantified reinforcement signal r , and the membership value O_{III} into (27)–(30).

Step 6) Reiterate from step 3).

The tuning rate for weights is opted to be $\eta w_j = 0.1$, and the tuning rate for the membership functions is opted to be $\eta a_i = \eta b_i = 0.008$. The minuscule values of tuning rates are culled so that there will be a smooth transition from one state to another.

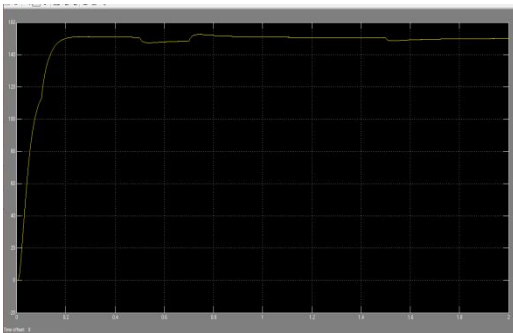

Fig. 6. Simulated starting speed responses of the drive. (a) Proposed NFC

V. SIMULATION RESULTS

The proposed simplified self-tuned NFC-predicated vector control of IM drive system has been implemented in authentic time utilizing the digital-signal-processor (DSP) board DS1104 [28]. This board is mainly predicated on 64-b floating-point MPC8240 processor with PPC603e core. The photograph of the experimental system is shown in Fig. 5. The genuine motor currents are quantified by the Hall-effect sensors and alimented back to the DSP board through the A/D channels. Rotor position is sensed by an optical incremental encoder of 1000-line resolution and is victualaed back to the DSP board through the encoder interface. The outputs of the DSP board are PWM logic signals, which a resent to the VSI switches through driver circuitry. The test IM is coupled to a dc engenderer, which is utilized as a load to the IM.

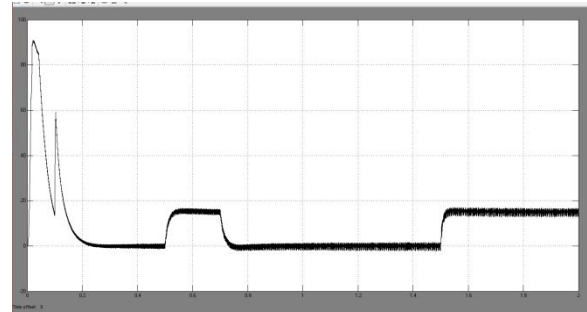

Fig. 7. Simulated speed responses of the IM drive at a step increase in load. (a) Proposed NFC. The NFC

and self-tuning algorithm are implemented through developing an authentic-time Simulink model. Then, the model is compiled and downloaded to the DSP board utilizing Control Desk software and authentic-time workshop. Since the proposed NFC has a simple structure, the highest sampling frequency can reach up to 14.3 kHz. In this paper, the sampling frequency is set to be 10 kHz so that the experiment becomes more proximate to practical application. For comparison purposes, a conventional two input NFC-predicated system is withal developed and experimentally implemented. The sampling frequency for the conventional NFC is found to be 5 kHz. For comparison purposes, a PI controller-predicated system is additionally developed and experimentally implemented. After tribulation and error, the proportional gain K_p and the integral gain K_i are culled as 0.1 and 0.02, respectively, so that there is no steady-state error and the settling time,

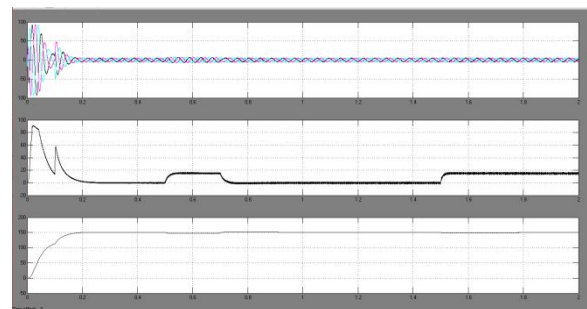

Fig. 8. Simulated speed responses of the IM drive with doubled rotor resistance. (a) Proposed NFC. (b) Conventional two-input NFC. (c) PI controller

.overshoot, and undershoot can be comparable to those of the NFCs. If the PI controller is made critically damped, it became too sluggish, and the response time is not even comparable to that of the NFCs. The performance of the proposed simplified NFC-based IM drive is investigated in simulation using Mat lab/ Simulink at different operating conditions [29]. Fig. 6(a)–(c) shows the simulated starting performances of the drive at full load with the proposed NFC, conventional two-input NFC, and PI controllers, respectively. It is clearly seen from these figures that the performance of the proposed simplified low computational NFC is similar to that of the conventional NFC and, at the same time, it is superior to that of the conventional PI controller in terms of overshoot and settling time. Fig. 7(a)–(c) shows the zoom-in view of the speed

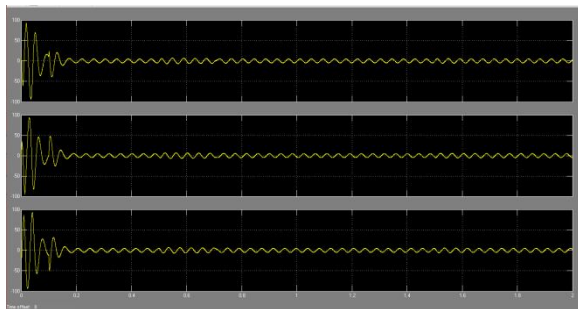

Fig. 9. Simulated speed responses of the IM drive at a step change of speed reference. (a) Proposed NFC. (b) Conventional two-input NFC. (c) PI controller. replications of the drive system with a step increase in the load from zero to rated level for the three controllers. It is found that the proposed simplified NFC can handle the load perturbation with lesser dip in speed as compared to both conventional NFC and PI controller. The variation of rotor resistance is a crucial issue for IM drive performance. So, in order to test the performance of the drive with parameter variations, the performance of the drive is tested for all three controllers with doubled rotor resistance, and the corresponding speed replications are shown in Fig. 8(a)–(c). Fig. 9(a)–(c) shows the speed replications of the drive system first with a step decrease in command speed from 180 to 150 rad/s, and then, a step increase in command speed from 150 to 180 rad/s utilizing the proposed NFC, conventional

NFC, and PI controller, respectively. In this test, the proposed NFC exhibits a little more sizable voluminous under shoot than the PI controller but no overshoot and less settling time. It is found that the performance of the proposed simplified NFC is virtually akin to that of the conventional NFC and, concurrently, it is superior to that of the conventional PINFC, (b) conventional two-input NFC, and (c) PI controller. controller as the PI controller takes longer time to reach the steady state. Predicated upon tests, it is evident that the proposed NFC does not decrement system performance significantly as compared to the conventional two-input NFC [13]. In advisement, the simplified NFC provides superior performance as compared to the conventional PI controller.

VII. CONCLUSION

In this paper, a novel and simplified low computational online self-tuning NFC-predicated speed control of IM drive has been developed and experimentally implemented for a laboratory 1/3-hp motor. In the proposed NFC, both weights and membership functions are tuned online predicated on operating conditions. The proposed controller can withal be applied to other types of motors of different sizes only by adjusting the tuning rates. The comparison of the proposed NFC with. It is found from the results that the proposed simplified NFC exhibits virtually the same performance of the conventional two-input NFC while reducing the computational burden significantly. The maximum sampling frequencies for the proposed NFC and conventional NFC have been found as 14.3 and 5 kHz, respectively, with the same DSP (DS1104) board. More over, the performance of the proposed NFC has been found superior to that of the conventional PI-controller-predicated IM drive. The proposed simplified self-tuned NFC-predicated IM drive system is found robust and could be an opportune candidate for authentic-time implementation of high-performance industrial drives.

REFERENCES

- [1] G.W. Chang, G. Espinosa-Perez, E. Mendes, and R. Ortega, "Tuning rules for the PI gains of field-oriented controllers of induction motors," *IEEE Trans. Ind. Electron.*, vol. 47, no. 3, pp. 592–602, Jun. 2000.
- [2] M. N. Uddin, T. S. Radwan, and M. A. Rahman, "Performances of fuzzy-logic-based indirect vector control for induction motor drive," *IEEE Trans. Ind. Appl.*, vol. 38, no. 5, pp. 1219–1225, Sep./Oct. 2002.
- [3] E. C. Shin, T. S. Park, W. H. Oh, and J. Y. Yoo, "A design method of PI controller for an induction motor with parameter variation," in *Proc. IEEE IECON*, 2003, vol. 1, pp. 408–413.
- [4] A. Miloudi and A. Draou, "Variable gain PI controller design for speed control and rotor resistance estimation of an indirect vector controlled induction machine drive," in *Proc. IEEE IECON*, 2002, vol. 1, pp. 323–328.
- [5] R. Krishnan and A. S. Bharadwaj, "A review of parameter sensitivity and adaptation in indirect vector controlled induction motor drive systems," *IEEE Trans. Power Electron.*, vol. 6, no. 4, pp. 695–703, Oct. 1991.
- [6] C. M. Liaw, J. B. Wang, and Y. C. Chang, "A fuzzy adapted field-oriented mechanism for induction motor drive," *IEEE Trans. Energy Convers.*, vol. 11, no. 1, pp. 76–83, Mar. 1996.
- [7] C.-M. Lin and C.-F. Hsu, "Adaptive fuzzy sliding-mode control for induction servomotor systems," *IEEE Trans. Energy Convers.*, vol. 19, no. 2, pp. 362–368, Jun. 2004.
- [8] T. C. Huang and M. A. El-Sharkawi, "High performance speed and position tracking of induction motors using multi-layer fuzzy control," *IEEE Trans. Energy Convers.*, vol. 11, no. 2, pp. 353–358, Jun. 1996.
- [9] Y. Tang and L. Xu, "Fuzzy logic application for intelligent control of a variable speed drive," *IEEE Trans. Energy Convers.*, vol. 9, no. 4, pp. 679–685, Dec. 1994.
- [10] F. F. Cheng and S. N. Yeh, "Application of fuzzy logic in the speed control of AC servo system and an intelligent inverter," *IEEE Trans. Energy Convers.*, vol. 8, no. 2, pp. 312–318, Jun. 1993.
- [11] T. Chen and T. T. Sheu, "Model reference neural network controller for induction motor speed control," *IEEE Trans. Energy Convers.*, vol. 17, no. 2, pp. 157–163, Jun. 2002.
- [12] F.-J. Lin and R.-J. Wai, "Adaptive fuzzy-neural-network control for induction spindle motor drive," *IEEE Trans. Energy Convers.*, vol. 17, no. 4, pp. 507–513, Dec. 2002.
- [13] M. N. Uddin and H. Wen, "Development of a self-tuned neuro-fuzzy controller for induction motor drives," *IEEE Trans. Ind. Appl.*, vol. 43, no. 4, pp. 1108–1116, Jul./Aug. 2007.
- [14] M. N. Uddin, "An adaptive filter based torque ripple minimization of fuzzy logic controller for speed control of a PM synchronous motor," *IEEE Trans. Ind. Appl.*, vol. 47, no. 1, pp. 350–358, Jan./Feb. 2011.
- [15] M. N. Uddin, M. A. Abido, and M. A. Rahman, "Development and implementation of a hybrid intelligent controller for interior permanent magnet synchronous motor drive," *IEEE Trans. Ind. Appl.*, vol. 40, no. 1, pp. 68–76, Jan./Feb. 2004.
- [16] G. Buja and M. P. Kazmierkowski, "Direct torque control of PWM inverter-fed AC motors—A survey," *IEEE Trans. Ind. Electron.*, vol. 51, no. 4, pp. 744–757, Aug. 2004.
- [17] M. N. Uddin and M. I. Chy, "A novel fuzzy logic controller based torque and flux controls of IPM synchronous motor," *IEEE Trans. Ind. Appl.*, vol. 46, no. 3, pp. 1220–1229, May/June. 2010.