

Comparison and Enhancement of Novel Wavelet Based Image Fusion



I Ravi Kumar

Research Scholar, Sree Visvesvaraya Institute of Technology & Science, Mahabubnagar A.P., India

lakshmi_ravikumar@yahoo.com

Abstract – It is a multi resolution fusion algorithm which combines aspects of region and pixel based fusion. We use multi resolution decompositions to represent the input images at different scales and introduce multi resolution or multi modal segmentation to partition the image domain at these scales. Then this segmentation is used to guide the subsequent fusion process using wavelets. A region based multi resolution approach allows us to consider low level as well as intermediate level structures and to impose data dependent consistency constraints based on spatial, inter and intra scale dependencies. The wavelets used in image fusion can be classified into three categories Orthogonal, Bi-orthogonal and non- orthogonal. Although these wavelets share some common properties, each wavelet also has a unique image decompression and reconstruction characteristics that lead to different fusion results. In this project the above three classes are being compared for their fusion results. Normally, when a wavelet transformation alone is applied the results are not so good. However if a wavelet transform and a traditional transform such as IHS transform or PCA transform are integrated for better fusion results may be achieved. Hence we introduce a new novel approach to improve the fusion method by integrating with IHS or PCA transforms.

The fusion results are compared graphically, visually and statistically and show that wavelet integrated methods can improve the fusion result, reduce the ringing or aliasing effects to some extent and make image smoother.

Medical Image Fusion has become an active research topic due to advances in sensor technology, microelectronics, processing techniques that combine information from different sensors into a single composite image for analysis, interrelation and better clinical diagnosis in much rapid and accurate way. The main objective of medical image fusion using wavelets is to create new image by regrouping the complementary information of multi sensor output.

Keywords – Multi-resolution, PCA Algorithm, Panchromatic Image, Fusion, Wavelet.

INTRODUCTION

Image fusion is a technique used to integrate a high resolution panchromatic image with low-resolution multispectral image to produce a high-resolution multispectral image, which contains both the high- resolution spatial information of the panchromatic image and the colour information of the multispectral image. Although an

increasing number of high-resolution images are available along with sensor technology development, image fusion is still a popular and important method to interpret the image data for obtaining a more suitable image for a variety of applications, such as visual interpretation and digital classification.

Image Fusion can Provide the Following Functions:

1. Sharpen the edges.
2. Improve geometric corrections.
3. Substitute the missing information image with signals from another image.
4. Replace defective data.

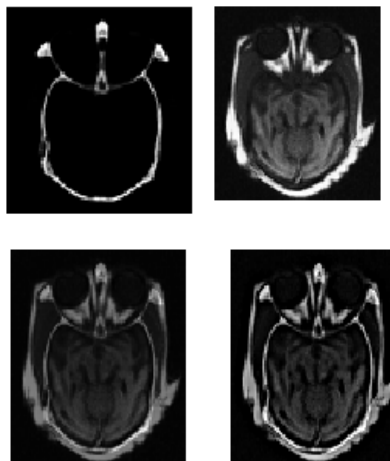

Fig 1 Image Fusion of CT Image and MR Image

Advantages of Image Fusion:

1. Improve system performance -detection, recognition, resolution.
2. Improve situation assessment.
3. Improve reliability by redundant information
4. Improve capability by complementary information



Fig 2 Fusion of Two Images

WAVELET USED IN THE IMAGE FUSION

❖ BASIC WAVELET TRANSFORM THEORY

In wavelet transformation, the basis functions are set of dilated and translated scaling functions.

$$\phi_{j,k}(n) = 2^{j/2} \phi(2^j n - k) \dots\dots\dots(1)$$

And a set of dilated and translated wavelet functions

$$\psi_{j,k}(n) = 2^{j/2} \psi(2^j n - k) \dots\dots\dots(2)$$

where $\phi(n)$ $\psi(n)$ are the scaling functions and the mother wavelet functions respectively.

❖ DIFFERENT WAVELETS USED IN IMAGE FUSION

(a) Orthogonal Wavelet:

The dilations and translation of the scaling function $\phi_{j,k}(x)$ constitute a basis for V_j and similarly $\psi_{j,k}(x)$ for W_j if $\phi_{j,k}(x)$ and $\psi_{j,k}(x)$ are orthonormal, they include the following property,
 $V_j \perp W_j$.

(b) Bi-Orthogonal Wavelet:

For Bi-orthogonal transform, perfect reconstruction is available. Orthogonal wavelets give orthogonal matrices and unitary transforms; bi-orthogonal wavelets give invertible matrices and perfect reconstruction. For bi-orthogonal wavelet filter, the Low pass and high pass filters do not the same length. The low pass and high pass filters do not have the same length. The low pass filter is always symmetric while high pass filter could be either symmetric or anti-symmetric.

(b) Non-Orthogonal Wavelet:

A torus is a kind of non-orthogonal wavelet that is different from orthogonal and bi-orthogonal. It is a 'stationary' or redundant transform, i.e. decimation is not implemented during the process of wavelet transform, while the orthogonal or bi-orthogonal wavelet can be carried out using either decimation or non-decimation mode.

Compared with other wavelet based fusion method, this method is relatively easy to implement. The limitation is that it uses a large amount of computer memory.

WAVELET BASED IMAGE FUSION METHOD

❖ ADDITIVE WAVELET BASED IMAGE FUSION METHOD

The whole process can be divided into four steps.

- a) Histogram match
- b) Wavelet decomposition
- c) Details information combination
- d) Inverse wavelet transforms

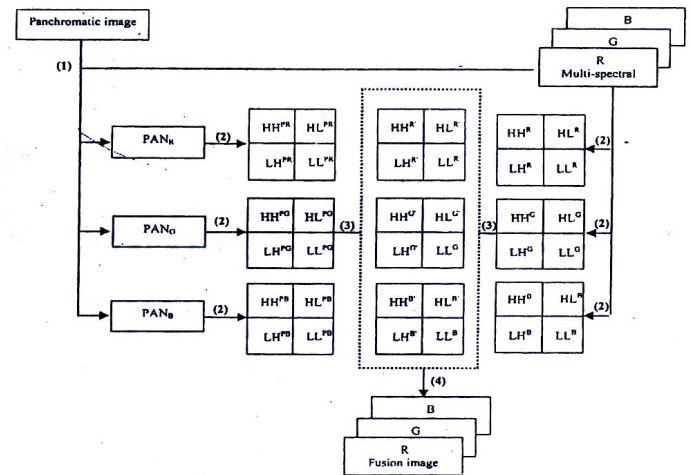

Fig 3 Work Flow of the Wavelet Based Fusion Method

- 1) Apply the histogram match process between panchromatic image and different bands of the multispectral image respectively, and obtain three new panchromatic images PANR, PANG, PANB.
- 2) Add the detail images of the decomposed panchromatic images at different levels to the corresponding details of different bands in the multispectral image and obtain the new details component in the different bands of the multispectral image.

- 3) Perform the wavelet transform on the bands of multispectral images, respectively and obtain the fused image. Integration of substitution method is divided into two parts:
 - a) Refers to substitution fusion method
 - b) Refers to the wavelet passed fusion method

The whole process consists of following steps:

- 1) Transform the multispectral image into the IHS or PCA components.
- 2) Apply histogram match between panchromatic image and intensity component and obtain new panchromatic image.
- 3) Decompose the histogram matched panchromatic image and intensity component to wavelet planes respectively.
- 4) Replace the LL^P in the panchromatic decomposition with the LL^I of the intensity decomposition; add the detail images in the panchromatic decomposition to the corresponding detail image in the panchromatic decomposition to the corresponding detail images of the intensity and obtain LL^I , LH^P , HH^P and HL^P .
 Perform an inverse wavelet transform, and generate a new intensity. Transform the new intensity together with hue, saturation components or PC1, PC2, PC3 back into RGB space.

ALGORITHM FOR PCA

1. Representation of Training Image:

Obtain face images A_1, A_2, \dots, A_M for training. Every image must of the same size ($N \times N$).

2. Computation of the Mean Image:

The images must be mean centered. The pixel intensities of the mean face image is obtained by adding the corresponding pixels from each image. The mean image can be computed as

$$m = 1/M \sum_{c=1}^M A_c \quad \dots \dots \dots (3)$$

3. Normalization Process of Each Image in the Database:

Subtract the mean image from the training images,

$$\bar{A} = A_c - m \quad \dots \dots \dots (4)$$

where $c = 1$ to M

4. Calculation of Covariance Matrix:

The covariance matrix, which is of the order of $N \times N$, is calculated as given by

$$C = 1/M \sum_{c=1}^M (A - m)^T (A - m) \quad \dots \dots \dots (5)$$

5. Calculation of Eigen Values and Eigen Vectors:

Find the Eigen values of the covariance matrix C by solving the equation

$$(C_{\lambda} - I) = 0 \quad \dots \dots \dots (6)$$

to calculate the Eigen values $\lambda_1, \lambda_2, \dots, \lambda_N$.

For specific Eigen value λ_i solve the system of N equations

$$(C_{\lambda_i} - I) = 0 \quad \dots \dots \dots (7)$$

To find the Eigen vector X Repeat the procedure for N Eigen values to find $X_1 \dots X_n$ Eigen vectors. The relation between Eigen vectors and Eigen value is given as $X_i^T (AA^T) X_i = \lambda_i$. Where X_i indicates the Eigen vectors and λ_i indicates corresponding Eigen values.

6. Sorting the Eigen Values and Eigen Vectors:

The Eigen vectors are sorted according to corresponding Eigen values in descending order. The Eigen vector associated with the largest Eigen value is one that reflects the largest variance in the image.

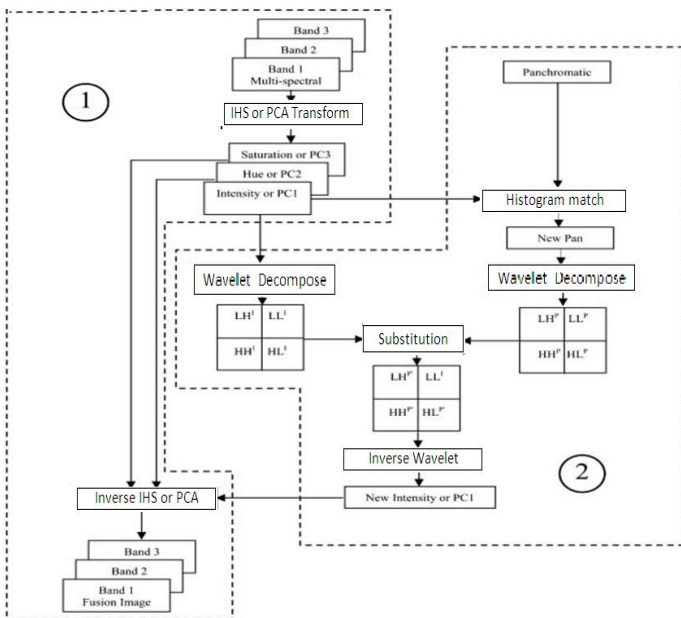

Fig 4. Flow of Fusion Based on Wavelet and Substitution Integration

7. Choosing the Best 'K' Eigen Vectors:

Keep only 'k' Eigen vectors corresponding to the 'k' largest Eigen values. Each face in the training set can be represented as a linear combination of the best 'k' Eigenvectors.

EXPERIMENTAL RESULTS

Five kinds of wavelet based fusion methods and two kinds of wavelet based integration method are implemented to test and compare their fusion results. All the fusion results are analyzed statistically by using correlation coefficients. The higher the value of the correlation coefficients, the more similar the fused image is to the corresponding original multispectral image.

CONCLUSION & FUTURE SCOPE

Compared wavelet based and wavelet integrated fusion methods. Wavelet based fusion extracts spatial details from high resolution bands. In this manner the color distortion can be reduced to a certain extent, but the fused image appears similar to a high pass filtered image. The colour appears not to be smoothly integrated into the spatial features. The wavelet integrated method can improve the fusion results, reduces the ringing or aliasing effects to some extents and make the whole image smoother.

Wavelet based image fusion can further be implemented to the following aspects:

- Fusion of Radar and optical data.
- Development of one method to evaluate the partial and spectral quality of a fused image.

REFERENCES

1. Digital image processing using Matlab – Rafael C. Gonzalez & Richard E. Woods Addison-Wesley an imprint of Pearson Education, 1st edition.
2. Introduction to wavelets and wavelet transforms BURRUS C.,S. Gopinath, R.A and GUO[Englewood cliffs, NT (prentice –Hall).
3. Enhancement of wavelet image fusion by G.Hong, Y.Zhang IEEE, 2008.
4. H. Li, B. S. Manjunath, S. K. Mitra, "Multisensor image fusion using the wavelet transform", Graphical Models and Image Processing, Vol. 57, No. 3, pp. 235–245, 1995.
5. S. Nikolov, P. Hill, D. Bull, and N. Ganagarajah, "Wavelets for image fusion", Wavelets in Signal and Image Analysis, Kluwer, Dordrecht, The Netherlands, pp. 213-244, 2001.
6. Slinger series in statistics I.T.Jolliffe Principal component analysis ,second edition.
7. G.H.Qu, D. L. Zhang, P. F. Yan "Information measure for performance of image fusion", Electronics Letters, Vol. 38, No. 7, pp. 313–315, 2002
8. Hong,G. and Zhang, y, 2003,High resolution image fusion based on wavelet and HIS transformations. in proceedings of the IEEE/ISPRS joint workshops on Remote sensing and data fusion over urban areas,2003,Berlin,pp.99-104.
9. G. Piella, "A general framework for multiresolution image fusion from pixel to regions", Information Fusion, Vol. 9, pp. 259–280, 2003.
10. Luo, R. C. und Kay, M. G.: Data fusion and sensor integration: State of the Art 1990s, in: Data fusion in robotics and machine intelligence, Abidi, M.

A. und Gonzalez, R. C. (Hrsg.), Academic Press, San Diego, 1992, S. 7-135

11. Mallat, S. G.: A theory for multi resolution signal decomposition: The wavelet representation, in: IEEE Trans. Pattern Analysis and Machine Intelligence, Vol. 11, No. 7, 1989, S. 674-693

12. A Theory for multi resolution signal Decomposition: the wavelet representation IEEE Transactions of analysis and machine intelligence, Mallat, G.S., 1989.

WEBSITES

<http://www.google.com>

<http://www.isca-speech.org/archive>

<http://www.ieee.org>

<http://www.wikipedia.org>

[http://www.wikipedia.org/wiki/fourier transform](http://www.wikipedia.org/wiki/fourier%20transform)