

Design and Analysis of DVR and D-Statcom Multi Level Converter in Distribution System

¹Sai Swethaja Paladugu, ²Sai Veeraju M.E,
 DEPARTMENT OF EEE SRKR ENGG COLLEGE

Abstract: The use of power electronics equipment has been rapidly increasing day by day and leading to several power quality problems. The different power quality problems we are facing the distribution system are Voltage sag, Voltage swell, Current harmonics, notch, spike, transients etc. Voltage sag is the most severe power quality problem which is affecting the industrial consumers; the best way to eradicate these power quality issues is by custom power devices. Dynamic Voltage restorer and d-statcom are the one of the CUP devices used to maintain power quality. In this paper the DVR and d-statcom are modeled and both of them are compared .The compensators are tested with various types of loads and sources performance is analyzed using MATLAB/Simulink software.

Keywords: power quality, Voltage sag/swell, CUPS DVR, D-Statcom.

INTRODUCTION

Power quality is the most important issue facing the present electrical engineering, with increasing in power electronic loads and variable loads it has become a major problem for industrial loads in terms of time and money. Hence there is the need of good power quality. In distribution system point there is also radial distribution in which loads are connected have different lengths short circuited at different points with different rating, this leads various in feeder impedance and increases losses in the distribution system. If the load is connected at end of long feeder it is called as Non- stiff source or weak ac supply and vise versa it is known as strong ac or stiff source. Several compensating devices came into existence in order to maintain power quality, such as capacitor banks, active and passive filters, and custom power devices. Among them in this paper we have highlighted about customer power devices. Custom power devices are power electronic based devices which are used to maintain power quality

problems. Two types of VSC's based CUPS are commonly used such as DVR (Dynamic Voltage Restorer) and D-statcom (Distributed statcom). Different control strategies have been proposed for DVR and D-Statcom, D-statcom includes reactive power compensation and voltage controlled mode operation and DVR includes open loop and closed operation. This paper assumes that a balanced and unbalanced load source supplies through the feeder. The compensators are designed in such a way that the compensator can improve power quality at PCC. And comparison is done using linear and non-linear loads and closed loop performance is analyzed and also a generalized multi level converter topology is considered and the modulation techniques based on cascaded multilevel inverter have been proposed for medium voltage distribution applications. Simulation is performed in both three phase and single phase system

DYNAMIC VOLTAGE RESTORER AND ITS OPERATING PRINCIPLE

A. Dynamic voltage Restorer

Dynamic voltage is one of the custom power device which is used for voltage sag/swell elimination and it consists of a VSC (Voltage Source Converter), storing device (Battery), Passive Filters, Injection transformer also known as Coupling transformer, In DVR VSC is made up with 6 IGBT switch which is used for conversion of dc link voltage into ac supply and there a battery which acts as dc link voltage and as well as storing agent and there placed a passive which is elimination of switching harmonics, when voltage source converter converts ac-dc or dc-ac we get ripple in the output supply of VSC and in order to eliminate those ripples passive filters are used and this output of the ripple filter is connected to the

injection transformer and which injects the filtered supply into the bus or feeder. When there is no disturbance in the system the injected transformer will be short circuited by the switch to decrease losses and increase cost effectiveness. The o/p of the DVR is completely depending upon the PWM technique and control method. The PWM generates signal by comparing sinusoidal signal with the carrier wave signal and sending appropriate signal to the Inverter.

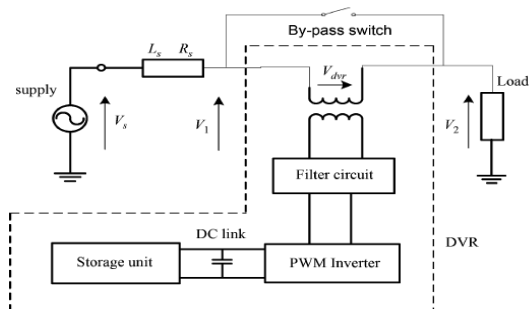

Fig 1: Schematic Circuit of Dynamic Voltage Restorer

When voltage drop occurred at load, DVR will inject a series Voltage through transformer so that the load voltage can be maintained at nominal value. In most of the sag conditions the DVR injects some active power to the system. Generally the operation of DVR can be categorized into two modes: 1) standby mode, 2) Injection Mode. Therefore the capacity of the storing device can be limiting factor especially during long-term voltage sag. In standby mode, DVR either in short circuit operation or inject small voltage to cover voltage drop due to transformer reactance losses. The DVR is turn into injection mode as soon as sag is detected and injects voltage in Series with the load with required magnitude and phase for compensation. The advantage of proposed technique is that less active power will be transferred from storage unit to distribution system. This results in compensation for deep voltage sag in the distribution system. The reference is considered as the source voltage and a carrier frequency is considered and both are compared with a comparator and the gating signals obtained are given to the gate terminals of DVR. The capability of injection of DVR system is 50% of nominal voltage; this allows DVR to successfully provide protection against sag to 50%

MODELING AND CONTROL OF D- STATCOM

DSTATCOM [1] is a voltage source converter (VSC) that is connected in shunt with the distribution system by means of a tie reactance connected to compensate the load current. In general, a coupling transformer is installed between the distribution system and the DSTATCOM for isolating the DSTATCOM from the distribution system. In addition, the device needs to be installed as close to the sensitive load as possible to maximize the compensating capability. Being a shunt connected device, the DSTATCOM mainly injects reactive power to the system. The role of DSTATCOM is specifically appreciated in case of a weak AC system [2]. The main components of DSTATCOM are – a VSC (voltage source converter), controller, filter, and energy storage device.

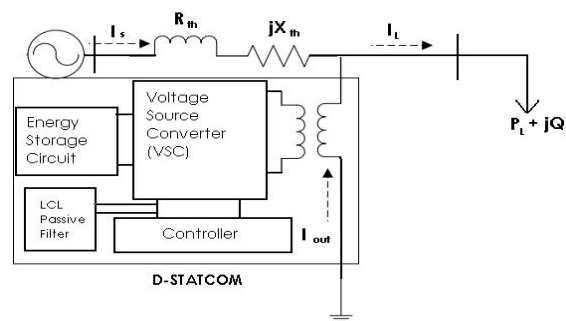

Fig 2 : System scheme for d-statcom

The system scheme of DSTATCOM is shown in Figure 2. These are briefly described as follows:

A. Isolation transformer: It connects the DSTATCOM to the distribution network and its main purpose is to maintain isolation between the DSTATCOM circuit and the distribution network.

B. Voltage source converter: A voltage source converter consists of a storage device and devices of switching, generating a sinusoidal voltage at any required frequency, magnitude and phase angle. In the DSTATCOM application, this temporarily replaces the supply voltage or generates the part of the supply voltage which is absent and injects the compensating current into the distribution network depending upon the amount of unbalance or

distortion. In this work, an IGBT is used as the switching device.

C. DC charging unit: This unit charges the energy source after a compensation event and also maintains the dc link voltage at the nominal value.

D. Harmonic filters: The main function of harmonic filter is to filter out the unwanted harmonics generated by the VSC and hence, keep the harmonic level within the permissible limit. Energy storage unit: Energy storage units like flywheels, batteries, superconducting magnetic energy Storage (SMES) and super capacitors store energy. It serves as the real power requirements of the system when DSTATCOM is used for compensation [3]. In case, no energy source is connected to the DC bus, then the average power exchanged by the DSTATCOM is zero assuming the switches, reactors, and capacitors to be ideal. Voltage dips can be mitigated by DSTATCOM, which is based on a shunt connected voltage source converter. VSC with pulse-width modulation (PWM) offers fast and reliable control for voltage dips mitigation.

VSC-BASED SHUNT AND SERIES COMPENSATORS

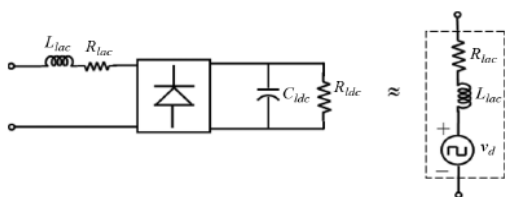

Fig 3: Voltage source type of the nonlinear load.

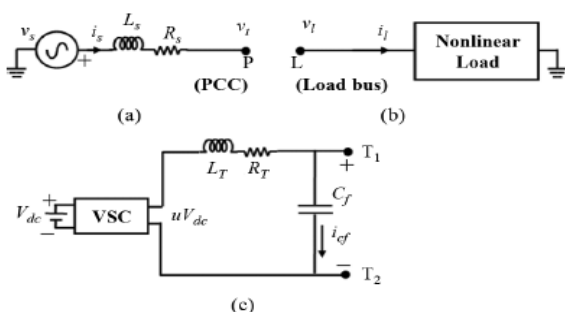

Fig 4: Compensator structure used for load voltage control for a single-phase equivalent of a distribution system. (a) Feeder. (b) Load. (c) Compensator.

Fig 4 shows the single line diagram of radial distribution system. Fig 4(a), Fig4(b) represents the source and the load respectively. The voltage source is connected point of the radial feeder. The point of common coupling (PCC), represented by point P, and the non-linear load is connected to the end of the radial feeder.. V_t represents the terminal voltage at pcc. Restoring the load bus voltage at point L under the conditions of sags and swells in the source is an essential requirement for the sensitive loads. Also, it is required to control this voltage against distortions due to the nonlinear load. A VSC-based generalized structure of the compensator used in a single-phase distribution system is shown in Fig. 4(c). Two types of compensators have been considered in this paper for load voltage control of the distribution system. In case the compensator is shunt type (i.e., DSTATCOM), the terminals P, L, and are joined together and is grounded. In case the compensator is series type (i.e., DVR), the terminal is connected to L and is connected to P. The compensator consists of a VSC that is interfaced to the distribution system. The voltage represents the net dc link voltage across the VSC. The variable is defined as the control input and represents the high-frequency switching of the inverter that assumes discrete values between and , depending upon the number of levels used in the multilevel converter topology. The symbol represents the equivalent inductance in the converter circuit. The resistance represents the equivalent loss component in the compensator. The filter capacitor is connected across the VSC to support the output voltage and provide filtering to the high-frequency switching components of the VSC. The currents flowing through the different branches are: the source current I_s , the load current I_l , and the current through the filter capacitor I_{cf} . The nonlinear load considered in this paper is assumed to be a bridge rectifier type with input impedance [4]. For a single-phase load as shown in Fig. 3, the output dc voltage of the bridge rectifier is fed to a resistive load supported by a parallel dc capacitor. This nonlinear load is called a voltage source type and is represented by a harmonic perturbation voltage source V_d , where V_{dc} is the Thevenin equivalent voltage source of this load. For a large dc capacitor and ac inductance, the input impedance approximately represents the Thevenin

equivalent impedance of this nonlinear load. The equivalent circuit is as shown in Fig. 3.

LOAD VOLTAGE CONTROL AND VSC MODULATION

In this paper for DVR and D-Statcom a simple output feedback loop is considered in order to control the load voltage. In this the actual Load voltage V_l is compared with the reference voltage V^* and the error signal E^* is passed to the low pass filter based derivate controller to switching pulses. The S-domain representation of the controller transfer function $G_c(s)$ between the output switching function S_e and the input error function e_l is defined as :

$$G_c(s) = S_e(s) / e_l(s) = K1 + (K2s / \alpha K2 + 1) \quad 4$$

Where error function e_l is defined as $e_l = V^* - V_l$ and $K1$ and $K2$ represents the proportional and derivate gains. The derivative action is associated with the first order low-pass filter to limit the amplification of the high-frequency noise and disturbances. The low pass filter action depends upon the filter coefficient α

The switching function S_e so obtained is modulated following the phase-shifted multicarrier PWM for the cascaded multilevel converter as given in [17]. The equivalent modulation method used with the two-level converter can be implemented as [11]

$$\begin{aligned} U(t) &= +1, se(t) - U_{tri}(t) > +h \\ U(t) &= -1, se(t) - U_{tri}(t) > -h \end{aligned} \quad 5(a,b)$$

U_{tri} is the carrier wave amplitude and frequency F_c . In order to eliminate the error loops a small hysteresis band is added.

The following transfer functions in Fig. 5 can be derived from (1) or (2) for the case of DSTATCOM or DVR, respectively

$$G_t(s) = U_l(s) / U(s) = c(sI - A)^{-1} \rightarrow b2 \quad (6)$$

$$G_t(s) = U_l(s) / U(s) = c(sI - A)^{-1} \rightarrow b3 + w \quad (7)$$

$$G_t(s) = U_l(s) / U_d(s) = c(sI - A)^{-1} \rightarrow b3 + w \quad (8)$$

Note that the matrices and in (7) and (8), respectively, are null matrices for the case of DSTATCOM.

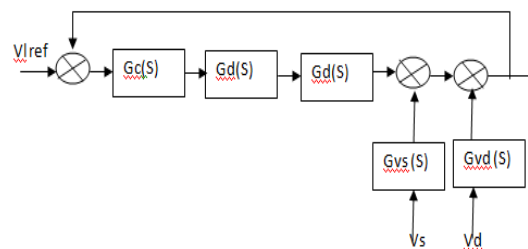

Fig 5 Block diagram of the load voltage control using DSTATCOM or DVR

SIMULATION IMPLEMENTATION ON SINGLE PHASE SYSTEM

A. Load Voltage Control in a Weak AC Supply System

A sinusoidal reference of 60 V(rms) is chosen for the load voltage control. Fig. 6 shows the comparison of the load voltage control using DSTATCOM with 2 kHz and 3 kHz of switching frequency using a two level VSC. Clearly the voltage tracking characteristic is better with 3-kHz switching frequency showing small tracking error at steady state. Therefore, for the remainder of this paper, the gating signal generated for complementary switches of the two-level inverter at a fixed switching frequency of 3 kHz using (4) are shown in Fig 7. With the absence of dvr and d-statcom source voltage distortion or harmonics is as shown in the the load voltage gets distorted and has a THD of 21.8% and a magnitude reduced by 10%, due to the nonlinear load and distorted supply voltage. Thus by placing d-statcom we can absorb the system can regain back to its original state the load voltage against variations in the source voltage and in the presence of the harmonic components of the nonlinear load, as shown in Fig. 10. The THD of the load voltage improves to 1.7% and controlled close to 60 V rms. Fig. 9 shows the load voltage control using DSTATCOM when the supply voltage rises by 20% (Voltage swell). Fig. 12 shows the load voltage control using the DVR that contains harmonics due to the high-frequency components of the load. The total harmonic distortion (THD) of the controlled load voltage is 10.2%. Clearly, we can absorb that DVR unable to control the voltage under non- stiff source Fig. 10 also shows the voltage sag condition of the source voltage from its nominal value. The feeder voltage is the mixed content of low-order

harmonics. DVR can able to compensate to the low-frequency components of the source as discussed earlier. Thus, the DVR controls the load voltage against variations in the source voltage and low-order source voltage harmonics.

B. Load Voltage Control in Strong AC Supply System

As discussed before the ac source is directly connected to the PCC. With this arrangement, the source voltage will directly flows across the load and there is no control of the DSTATCOM over variations in the source voltage. The DVR is useful in this situation. Fig. 11 shows the load voltage control using DVR when the feeder is strong source. The THD of the controlled load voltage is 1.9%. In this case, the DVR control is effective against the variations in the source voltage and harmonics of the nonlinear load. The source voltage again shows the voltage dip condition in Fig. 11. Fig. 12 shows the load voltage control against sag in the source voltage by the DVR for the stiff supply system. The figure also shows the changing condition of the source voltage. From the aforementioned experimental results, it is verified that the DSTATCOM is a suitable compensator for the nonlinear load supplied from the non-stiff source. For the other case, the DVR is a suitable compensator when the nonlinear load is supplied from the stiff source.

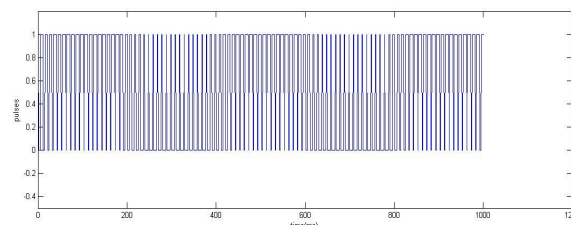

Fig 7 Switching pulses

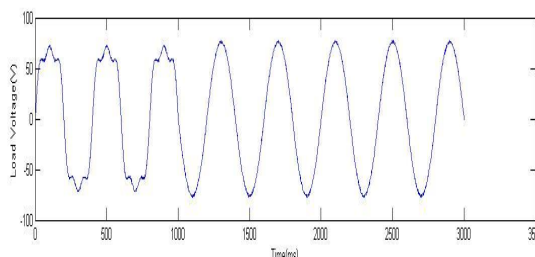

Fig 8: Load voltage

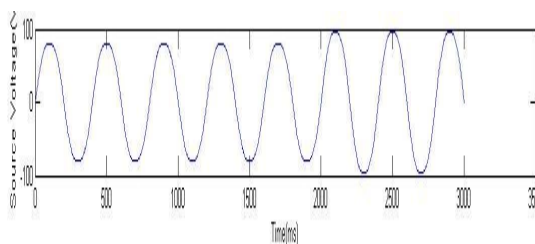

Fig 9: Source voltage

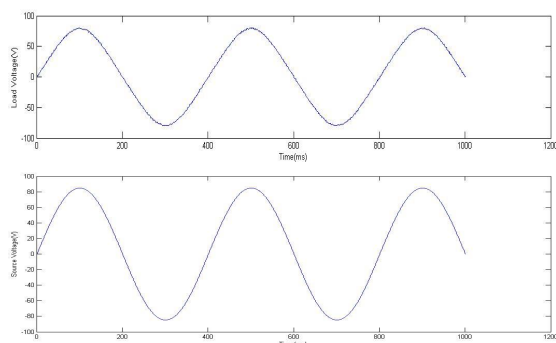

Fig 6: Load voltage, Source voltage

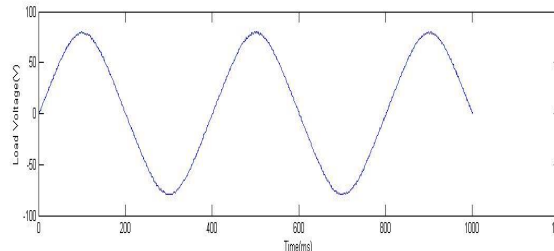
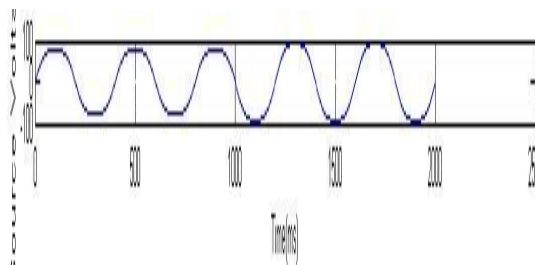

Fig 10: Load voltage, Source voltage

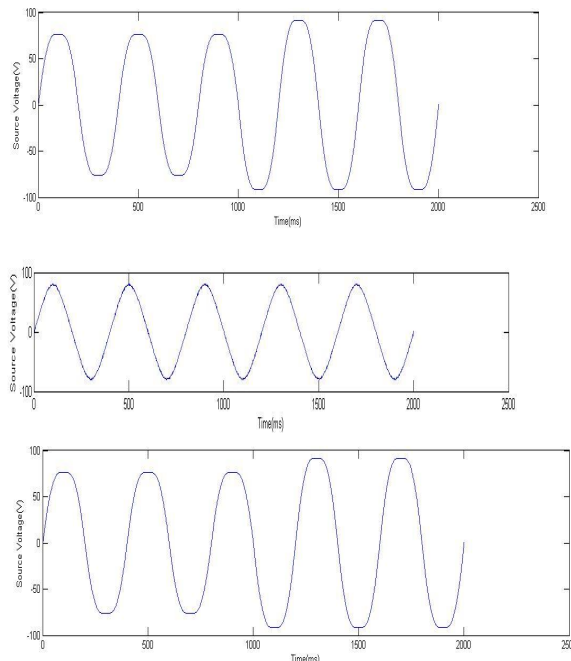

Fig 11 Source voltage, source load

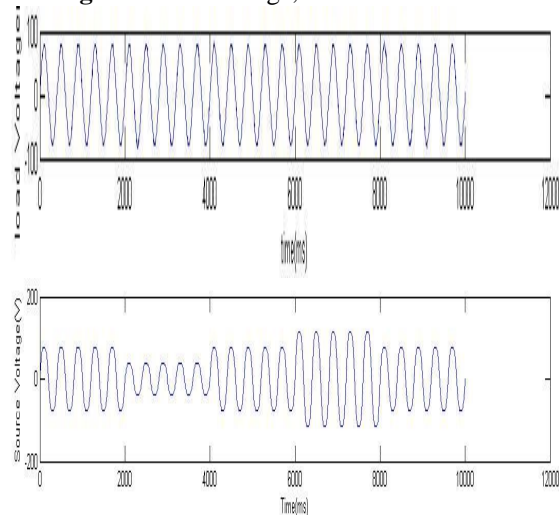

Fig 12: Load voltage Source voltage

SIMULATION STUDIES ON THE THREE-PHASE DISTRIBUTION SYSTEM

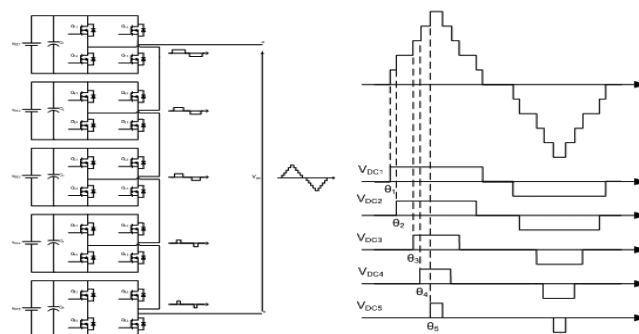

Fig. 13. Single -phase eleven -level cascaded transformer H-bridge VSC.

This section, the load voltage of a three-phase four-wire 11-kV distribution system is controlled. The converter topology based on the seven-level cascaded transformer multilevel inverter as proposed in and shown in Fig. 13 has been used for the DSTATCOM and the DVR.

A Load Voltage Control Using DSTATCOM

The feeder parameter as taken shows that the supply system is weak. Therefore, a DSTATCOM is used here to control the load voltage. The eleven-level multicarrier PWM has been used with three H-bridges per phase, as shown in Fig. 13. A carrier frequency of 1.0 kHz is considered. In this case of the seven-level inverter, the effective switching frequency is 6.0 kHz and this leads to the effective switching delay 0.0833 ms, where 7 for the eleven level inverter. The controller parameters are chosen, 10, 0.001 and 0.01, for 0.1 ms so that it satisfies. The net dc link voltage used in the model of the DSTATCOM is 19.8 kV, where the transformer is turns ratio and is equal to 3.0 here. A PI controller has been used to control the dc link voltage to 2.2 kV. The reference amplitude for the load voltage is chosen as 8.98 kV for each phase that leads to the 11 kV line-line voltages. Fig. 14(a) shows the load bus voltage. The voltage is distorted and unbalanced when DSTATCOM is not connected. Also, there is a 25% voltage dip in phase-b. The DSTATCOM is connected at 0.2 s, and the voltage becomes balanced and sinusoidal. The eleven-level inverter output cascaded at the primary of the transformer is shown in Fig. 14(b). The voltage is controlled against unbalancing in the source and harmonic distortion due to the nonlinear load.

B. Load Voltage Control Using DVR

To illustrate the performance of DVR, the same system parameters are considered again. However, it

is assumed that an industrial load is directly connected to the 11-kV bus so that the supply system is strong with the feeder impedance of p.u. The same multilevel converter topology as shown in Fig. 13 has been used for the DVR. The rest of the parameters are considered the same except for the cascading transformer voltage ratio of 2.0 kV/2.0 kV. The common dc link voltage of the VSC is supported using the three-phase diode bridge rectifier. The rectifier is supplied from a three-phase transformer that is connected to the PCC of the same distribution system feeder. The load voltage is controlled using the pre sag/swell reference angle method. The supply is again considered unbalanced. Sag of 25% is initiated in the supply at 0.1 s that lasts until 0.18 s. Similarly after normalcy, a swell of 15% is generated at 0.26 s that lasts until 0.3 s. The load voltage is controlled to a constant voltage of near sinusoidal wave shape against unbalancing and sag/swell in the supply voltage as shown in Fig. 15.

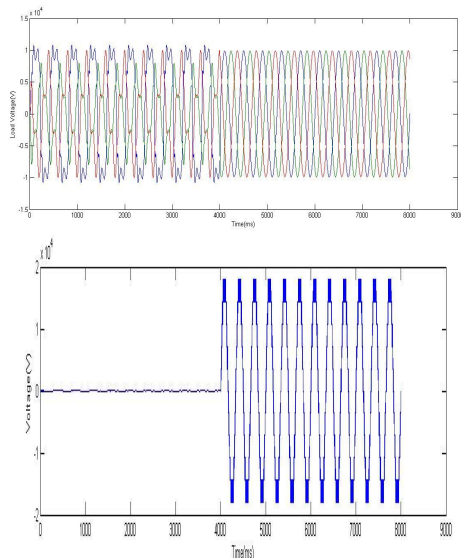

Fig. 14. (a) Load voltage for three-phase distribution system, DSTATCOM is connected at 0.2 s. (b) Eleven-level inverter output voltages.

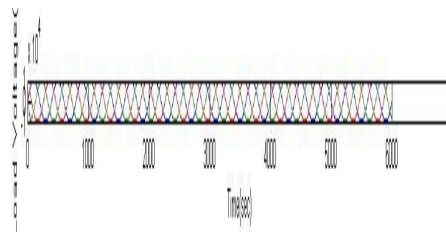
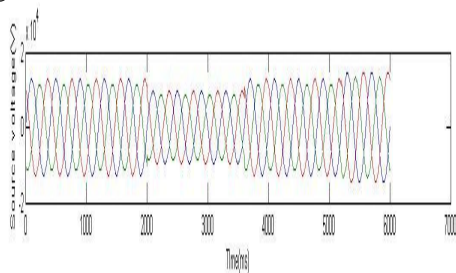

Fig. 15. Three-phase load voltage control using the DVR against sag and swell in the terminal voltage, the supply is unbalanced with 25% sag from 0.1 to 0.18 s and 15% swell from 0.26 to 0.30 s.

CONCLUSION

In this work, the investigation on the role of DSTATCOM and DVR is carried out to improve the power quality in distribution networks with static linear and non linear loads. Test system is analyzed and results are presented in the simulation section. The results shows the satisfactory performance of DSTATCOM and DVR in the distribution networks under different fault conditions and it can be concluded that DSTATCOM and DVR effectively improves the power quality in distribution networks with static linear. The generalized converter topology based on cascaded multilevel inverter using multicarrier phase-shifted PWM can be used for the load voltage control of an MV distribution system, following the proposed control algorithm. The results for the three-phase load voltage control have been verified for an 11-kV distribution system, using eleven-level cascaded transformer multilevel converter topology, through simulations.

REFERENCES

- [1] Rajesh Gupta, Arindam Gosh, Avinash Gupta "Performance Comparison of VSC based shunt and series compensators used for load compensation in distribution systems". IEEE Trans on Power Delivery, Vol 26 No 1, Jan 2011
- [2] P. R. Sánchez, E. Acha, J. E. O. Calderon, V. Feliu, and A. G. Cerrada, "A versatile control scheme for a dynamic voltage restorer for power-quality improvement," IEEE Trans. Power Del., vol. 24, no. 1, pp. 277–284, Jan. 2009.