

# Design and Characterization of E-Shape Microstrip Patch Antenna for Wireless Communication



Divya.R<sup>1</sup>, Student, Priya.M<sup>2</sup>, Assistant professor  
 Department of Electronics and Communication  
 Prathyusha Institute of Technology and management  
 Chennai, TamilNadu  
*E mail: tgmdivya@gmail.com*

**ABSTRACT** - The area of microstrip antennas has seen some inventive work in recent years and is one of the most dynamic fields of antenna theory. The ever increasing need for mobile communication and the emergence of newer technologies require an efficient design of antenna of smaller size for wider frequency range applications such as Wi-Max. The main aim of this paper is increase the impedance bandwidth of the microstrip patch antenna. A low profile wideband unequal E-shaped microstrip patch antenna for Wi-Max application is proposed in this paper. This proposed antenna is made by using the microstrip feeding method. Its bandwidth is further increased by introducing composite effect of stacking of patches with partial grounding. The antenna is designed and simulated by three-dimensional electromagnetic field software HFSS'12. The properties of the antenna such as bandwidth, S parameter, VSWR have been investigated.

**Keywords:** microstrip feed, microstrip patch antenna, rectangular slot, Wi-Max, VSWR (Voltage Standing Wave Ratio), HFSS (High Frequency Structure Simulator).

## I. INTRODUCTION

In wireless communication, there are several types of micro strip antennas the most common of which is the micro strip patch antennas. Microstrip antennae consist of very small conducting patch built on a ground plane separated by dielectric substrate. The patch antenna idea was first proposed in the early 1950s, but it was not until the late 1970s that this type of antenna attracted serious attention of the antenna community.

The microstrip patch antenna offers the advantages of low profile, ease of fabrication, and compatibility with integrated circuit technology. They can be designed to operate over a large range of frequencies (1- 40 GHz) and easily combine to form

linear or planar arrays. It can generate linear, dual, and circular polarizations. The microstrip antenna has different feeding techniques like probe fed, aperture coupled, proximity and insert feed.

As conventional antennae are often bulky and costly part of an electronic system, the micro strip antennae considered as an engineering breakthrough for compact communication devices and systems especially for remote uses where compactness is much desirable feature. However, conventional microstrip patch antenna suffers from very narrow bandwidth. This poses design challenge for the microstrip antenna designer to meet the broadband requirements. Several techniques have been applied to overcome this problem such as using thick substrate with low dielectric constant, parasitic patch loading on the same layer with the main patch, stacked multilayer patches, U-slot and E- slot etched on the same patch and L-probe feeding.

The proposed antenna is designed for 2.45GHz frequency with stacked unequal E-shape patch with partial grounding. The proposed antenna is made by using microstrip feed and simulated by HFSS'12. A typical patch antenna is shown in figure 1.1.

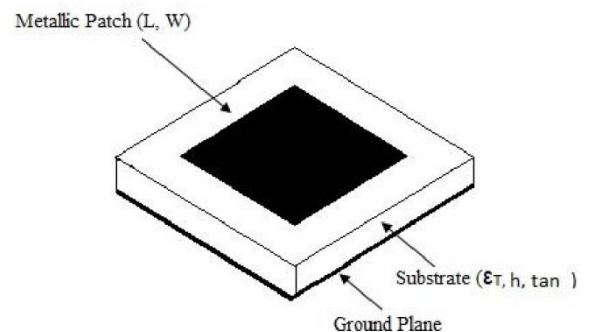

Figure 1.1 Microstrip Antenna

In this paper, reduced ground plane structure and a stacking of unequal E-shape patch is investigated for enhancing the impedance bandwidth on the

substrate Duroid 5880 (dielectric constant is 2.2). The paper is organized in the following sections the design of wideband microstrip patch antenna is

## II. ANTENNA DESIGN

The geometry of the proposed stacked unequal E-shape patch antenna is shown in Fig.2. It consists of an unequal E-shape patch antenna, a rectangular patch, partial grounding and a microstrip feed. The heights of the substrates are 6.7(mm).

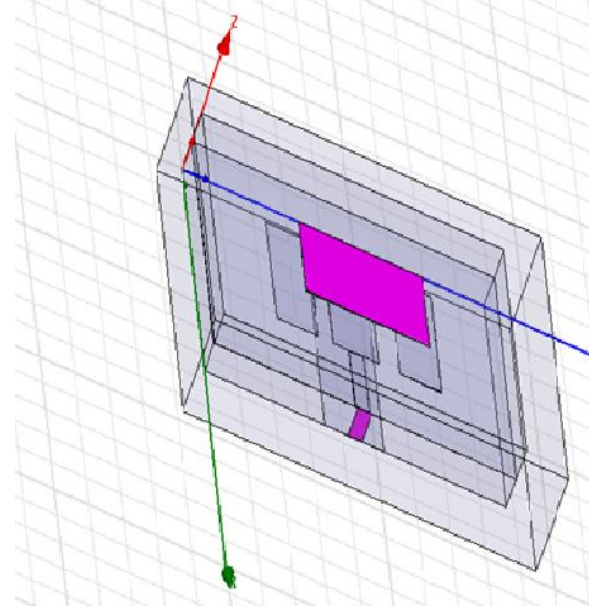

Fig. 2. Actual HFSS model (top view)

The design process was start with HFSS' 12, aiming a bandwidth ( $S_{11} \leq 10\text{dB}$ ) between 2-5 GHz for WLAN and Wi-Max applications. The important parameters involved in the design process are dimension of rectangular patch ,two parallel slots of E-shaped patch, feed point position and the separation between patches .In general , the centre wing and the two side wings of the E-shaped patch forms two resonance frequencies and prudent selection of these frequencies can enhance the impedance bandwidth .

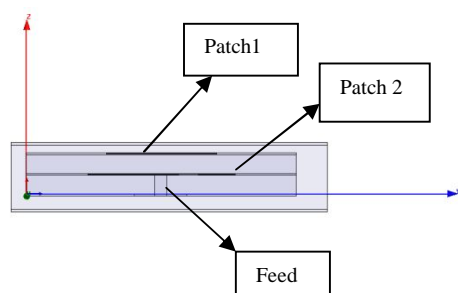

Fig.3.Actual HFSS model (side view)

presented in section -II . The results and discussion are given in section- III.The conclusions are presented in section -IV. The above figure shows that the antenna having stacking of patches and the feed will be microstrip feed.

Table 1. Material used for patch antenna

	Material
patch	pec
Substrate	Duroid 5880 ( $\epsilon_r = 2.2$ )

### A. DESIGN CONSIDERATIONS

There are three important parameters which are to be considered carefully for the designing a rectangular microstrip patch antennae for wireless communication.

- Frequency of operation ( $f_0$ ): The Mobile Communication Systems (Wi-MAX) uses the frequency range from 2100-5600 MHz . Hence the antennae designed must be able to operate for this frequency range. The default resonant frequency chosen for this research design simulation is 2.45 GHz.
- Dielectric constant of the substrate ( $\epsilon_r$ ): The dielectric material chosen for this design is Duroid 5880 which has dielectric constant of 2.2 .
- Height of dielectric substrate ( $h$ ): For the Microstrip patch antennae to be used in cellular phones, it is essential that the antennae are kept light and compact .Hence, the height of the dielectric substrate is chosen as 2.87 mm.

Hence, the essential parameters for the above explained design are chosen as  $f_0 = 2.45$  GHz, Duroid 5880 = 2.2 and  $h = 2.87$  mm.

### B. DESIGN PROCEDURE

#### Step 1: Determination of the Width (W)

The width of the Microstrip patch antenna is given by

$$W = \frac{c}{2f_0 \sqrt{\frac{\epsilon_r + 1}{2}}}$$

By substituting  $c = 3 \times 10^8$  m/s,  $\epsilon_r = 2.2$  and  $f_0 = 2.4$  GHz, it can be easily determined that  $W = 48.0$  mm.

Step 2: Determination of effective dielectric constant ( $\epsilon_{reff}$ )

The effective dielectric constant is represented by

$$\epsilon_{reff} = \frac{\epsilon_r + 1}{2} + \frac{\epsilon_r - 1}{2} \left[ 1 + 12 \frac{h}{W} \right]^{-\frac{1}{2}}$$

By substituting  $\epsilon_r = 2.2$ ,  $W = 34.0$  mm and  $h = 2.87$  mm, it can be determined that  $\epsilon_{reff} = 2.452$

Step 3: Determination of the effective length ( $L_{eff}$ )

The effective length is given by

$$L_{eff} = \frac{c}{2f_0 \sqrt{\epsilon_{reff}}}$$

By substituting  $\epsilon_{reff} = 2.452$ ,  $c = 3 \times 10^8$  m/s and  $f_0 = 3.5$  GHz, it can be determined that  $L_{eff} = 0.02736$  m = 27.36 mm.

Step 4: Determination of the length extension ( $\Delta L$ )

The length extension may be represented by

$$\Delta L = 0.412 h \frac{(\epsilon_{reff} - 0.3) \left( \frac{W}{h} + 0.264 \right)}{(\epsilon_{reff} - 0.258) \left( \frac{W}{h} + 0.8 \right)}$$

By substituting  $\epsilon_{reff} = 2.452$ ,  $W = 34.0$  mm and  $h = 2.87$  mm, it can be determined that  $\Delta L = 1.4201$  mm.

Step 5: Determination of actual length of patch ( $L$ ):

The actual length is obtained by using expression

$$L_{eff} = L + 2\Delta L$$

By substituting  $L_{eff} = 27.36$  mm and  $\Delta L = 1.4201$  mm, the actual length can be determined as  $L = 36$  mm. In the foregoing mathematical computations, the patch parameters have been designed for the substrate Duroid 5880 with dielectric constant 2.2.

The above figure shows that the designed unequal E-shape patch antennas having the minimum return loss at 2.32 and 3.8 GHz.

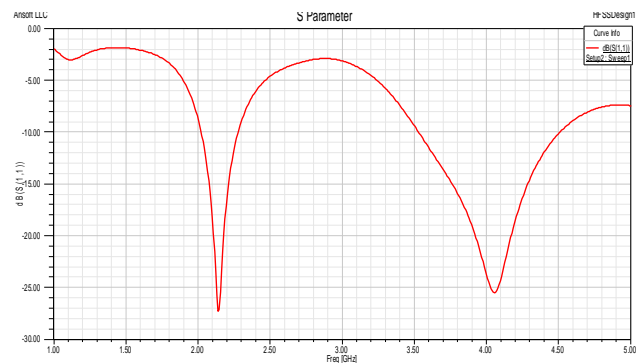

Fig.5 Return loss( $S_{11}$ ) parameter of the stacked antenna

The above figure shows that the designed unequal E-shape stacked patch antenna with partial grounding having the minimum return loss at 2.15 and 4 GHz.

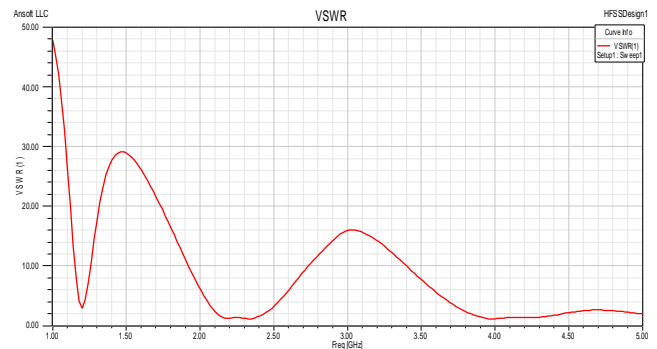

Fig.6 VSWR of the unequal E-shape antenna

### III.SIMULATION RESULTS AND DISCUSSIONS

For simulation we used HFSS'12 of ansoft, which is very good for RF antennas. After simulating the design the result we got is as follows.

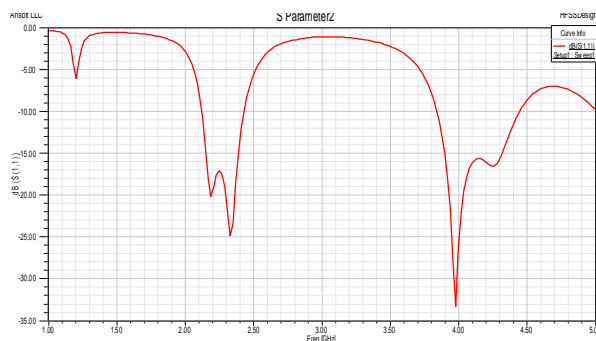

Fig.4 Return loss ( $S_{11}$ ) parameter of the unequal E-shape antenna

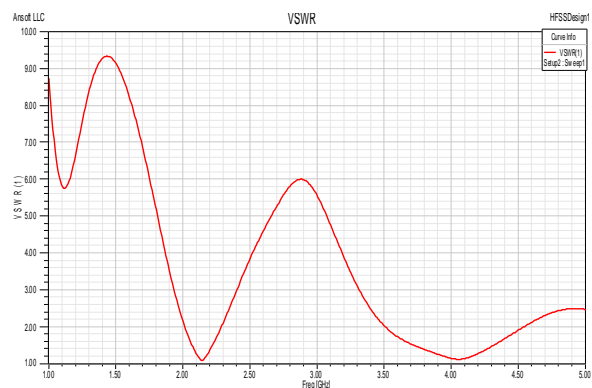

Fig.7 VSWR of the stacked antenna

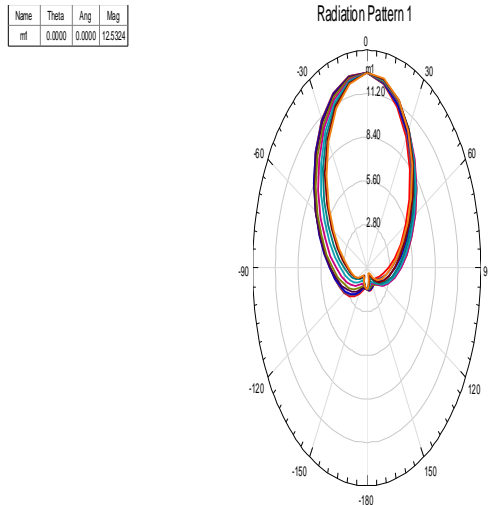

Fig.8. Radiation pattern of the stacked antenna

Fig.8 shows the radiation pattern of the unequal stacked patch antenna with partial grounding providing the gain of the antenna as 12.7dB.

Table 2 .The comparison between the performances of designed patch antenna is shown below:

Patch shape	Resonant frequency (GHz)	Return Loss (dB)	VSWR	band width (MHz)
Unequal E-shape patch	2.32	-24.4	1.5	280
	3.9	-29.5	1.12	620
Stacked unequal E-shape patch with partial grounding	2.15	-27.2	1.06	290
	4	-25.5	1.2	1050

The above table shows that the bandwidth is wider than the conventional unequal E-shape patch antenna .The dimension of rectangular patch as well as the shift of microstrip feed point location has been optimized to achieve this bandwidth and it can be used for WLAN and Wi-Max applications.

#### IV. CONCLUSION

A wideband stacked unequal E-shape patch has been presented in this paper .simulations and results of the stacked unequal E-shape patch with partial grounding have been provided a useful design for an antenna operating at the frequency of 2-2.29 GHz for WLAN and 3.53-4.58GHz for Wi-Max applications . The return loss of the proposed antenna is less than -10dB and the increase in bandwidth in comparison to the unequal E-shape patch antenna with stacked

unequal e-shape patch antenna with partial grounding is 17.6%.

It is concluded that the proposed stacked unequal E-shape patch with partial grounding antenna enhanced the impedance bandwidth than the unequal E-shape patch antenna.

#### REFERENCES

- [1] Kashwan .K. R, IEEE Member, Rajeshkumar.V, Gunasekaran T and Shankar K R “Design and Characterization of Pin Fed Microstrip Patch Antenna” IEEE Eighth International Conference on Fuzzy Systems and Knowledge Discovery (FSKD) 2011.
- [2] Mamta Devi Sharma , Abhishek Katariya , Dr. R. S. Meena “E shape patchmicrostrip antenna For WLAN application using probe feed and aperturefeed ” IEEE International Conference on Communication Systems and Network Technologies 2012.
- [3] M.T.Ali,Aizat,I.Pasya,M.H.Mazlan Zaharuddin and NorsuzilaYaacob “ E-shape Microstrip patch Antenna for Wideband Applications” IEEE International RF and Microwave Conference 2011.
- [4] Dr.Anubhutihare ,Rajesh Nema,PuranGour, “New multiband E-shape microstrip patch antenna on RT DUROID 5880 substrate and RO4003. substrate for pervasive wireless communication” International journal of computer applications 2010.
- [5] Geetanjali ,Rajesh khanna , “ Reduced ground plane E-shaped wideband micro strip patch antenna for WLAN systems “ IOSR journal of Engineering ”.
- [6] M.A.Matin ,M.A.Mohd Ali ,“ Design of broadband stacked E- shaped patch antenna ” IEEE 2008.
- [7] PromodKumar.M, Rajeev Jyothi, SagiSravan Kumar ,VSK Reddy ,“Simplified and efficient technique for designing of broadband patch antenna ” IEEE 2009.
- [8] Shobhit K.Patel, Y.P.Kosta “ E-shape microstrip patch Antenna design for GPS application ” IEEE 2011.
- [9] Hang wong,Kwai-Man luk,Chi Hou Chan ,Quan Xue,Kwok Kan So,Hau Wah Lai “ Small antennas in wireless communications ” IEEE 2012.
- [10] Kai-Fong Lee,Kin-fai Tong “ Microstrip patch antennas-basic characteristics and some recent advances ” IEEE 2012.