

A POSITIVE BUCK-BOOST CONVERTER CONTROLLED BY DIGITAL COMBINATION OF BUCK AND BOOST CONVERTERS TO IMPROVE THE OUTPUT TRANSIENTS



¹Nanda Kumar.K, ²Giri.R

¹AP, Department of EEE, Hindustan University. nandak@hindustanuniv.ac.in

²AP (SG) Department of EEE, Hindustan University. minmalai@gmail.com

Abstract-This project is a highly efficient and novel control strategy for improving the transients in the output voltage of a dc-dc positive buck-boost converter which is required for low-power portable electronic applications. The proposed control technique can regulate the output voltage for variable input voltage (higher, lower, or equal to the output voltage). There are several existing solutions to these problems, and selecting the best approach involves a tradeoff among cost, efficiency, and output noise or ripple.

In the proposed method, instead of instantaneous transition from buck to boost mode, intermediate combination modes consisting of several buck modes followed by several boost modes are utilized to distribute the voltage transients. This is unique of its kind from the point of view of improving the efficiency and ripple content in the output voltage.

Keywords- buck-boost converter, dc-dc

I. INTRODUCTION

A very common power-handling problem, especially for portable applications, powered by batteries such as cellular phones, personal digital assistants (PDAs), wireless and digital subscriber line (DSL) modems, and digital cameras, is the need to provide a regulated non inverting output voltage from a variable input battery voltage. The battery voltage, when charged or discharged, can be greater than, equal to, or less than the output voltage. But for such small-scale applications, it is very important to regulate the output voltage of the converter with high precision and performance. Thus, a tradeoff among cost, efficiency, and output transients should be considered.

A common power-handling issue for space-restrained applications powered by batteries is the regulation of the output voltage in the midrange of a variable input battery voltage. Some of the common examples are 3.3 V output with a 3–4.2 V Li cell input, 5 V output with a 3.6–6 V four-cell alkaline input, or a 12 V output with an 8–15 V lead-acid battery input.

With an input voltage range that is above and below the output voltage, the use of a buck or a boost converter can be ruled out unless cascaded. Cascaded combination of converters results in cascaded losses and costs; therefore, this approach is seldom used. In such a range of power demand, the transition of dc voltage from one level to another is generally accomplished by means of dc/dc power converter circuits, such as step-down (buck) or step-up (boost) converter circuits. There are various topologies such as inverting buck-boost converters, single-ended primary inductance converters (SEPICs), Cuk converters, isolated buck-boost converters, and cascaded buck and boost converters, which can be implemented to maintain a constant output voltage from a variable input voltage.

The important points of concern for such low-voltage-range power supplies are output ripple, efficiency, space, and the cost. The aforementioned topologies are generally not implemented for such power supplies due to their lower efficiency, higher size, and cost factors. The most difficult problem is the spikes in the output voltage, which causes the converter to lose efficiency during the transition from buck mode to the boost mode. Cost, size, switching speed, efficiency, and flexibility all need to be considered in designing such power supplies. The advantage of having higher efficiency is longer runtime at a given brightness level from the same set of batteries.

A. PROPOSED SYSTEM

- A highly efficient control strategy to control a pulse width modulation (PWM) dc/dc positive buck–boost switching converter has been illustrated in this paper.
- The proposed control scheme can regulate the output voltage for an input voltage, which changes based on the charge status of the battery supply.
- The technique introduced in this paper is unique of its kind in improving the efficiency and the ripple content of the output voltage for a positive buck–boost converter whenever smooth transition is needed from the buck mode to the boost mode and the concept of DCPC is introduced.

II. BASIC BUCK-BOOST CONVERTER

The buck–boost converter is a type of DC-DC converter that has an output voltage magnitude that is either greater than or less than the input voltage magnitude. It is a switch mode power supply with a similar circuit topology to the boost converter and the buck converter. The output voltage is adjustable based on the duty cycle of the switching transistor. One possible drawback of this converter is that the switch does not have a terminal at ground; this complicates the driving circuitry. Also, the polarity of the output voltage is opposite the input voltage. Neither drawback is of any consequence if the power supply is isolated from the load circuit (if, for example, the supply is a battery) as the supply and diode polarity can simply be reversed. The switch can be on either the ground side or the supply side.

A. PRINCIPLE OF OPERATION

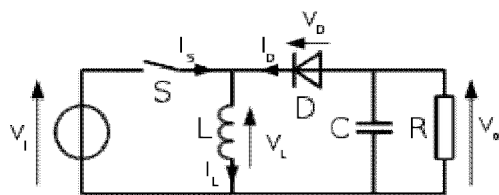

Fig 1 Schematic of a Buck–Boost converter.

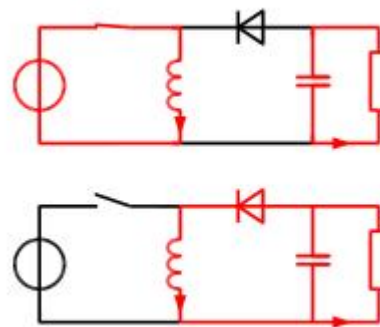

Fig 2 working of the basic buck boost converter

The diagram shows the working of the basic buck boost converter. The two operating states of a buck–boost converter: When the switch is turned-on, the input voltage source supplies current to the inductor and the capacitor supplies current to the resistor (output load). When the switch is opened (providing energy is stored into the inductor), the inductor supplies current to the load via the diode D.

while in the On-state, the input voltage source is directly connected to the inductor (L). This results in accumulating energy in L. In this stage, the capacitor supplies energy to the output load; while in the Off-state, the inductor is connected to the output load and capacitor, so energy is transferred from L to C and R.

III. PROPOSED NEW METHOD

The proposed method is to add interface modes, which are a combination of buck and boost operating topologies. When the input voltage is considerably higher than V_1 , the converter operates in purely buck mode. However, during the time period, where the input voltage is between V_1 and V_2 , threshold voltage, the combination mode A comes into operation, followed by the buck–boost mode for the voltage range V_2 and V_3 . In the voltage range V_3 and V_4 , the converter operates in the combination mode B. Finally, for the input voltages below V_4 , the converter operates purely in the boost operating mode. By adding the combination modes A and B during the time periods “T1” and “T3” just before and after the stage, where $v_{in} \approx v_{out}$, the transient at the output of the converter can be improved significantly.

Operation of the converter in buck– boost mode decreases the efficiency of the converter. In order to improve its efficiency, buck–boost mode should be eliminated. This is another major contribution of this paper. In that case, time periods T_2 will be eliminated and the operation mode will change from buck to the boost through intermediate combination modes. Each combination mode is a combination of several buck and boost operating topologies. In the proposed method, instead of a sudden transition from buck operating mode to a buck–boost operating mode, a combination of buck and boost operating topologies is applied to distribute the voltage transient and, therefore, obtain smoother output waveform. This is the concept of digital combination of power converters (DCPCs), which is applied to a non-inverting buck–boost converter in this paper. In combination mode A, the number of buck operating topologies is usually higher than the number of boost operations. Similarly, in the combination mode B, the number of boost operating modes will be higher than buck operations.

A. DIGITAL COMBINATION OF POWER CONVERTERS

Control approach based on DCPC improves the dynamic response of the converter during transients by switching between different converter topologies to spread out the voltage spikes that are an inevitable part of the transients. Fig. 3 demonstrates the block diagram of the proposed approach. In this figure, converter topology control (CTC) controls the operating topologies of the converter. In addition, transition control (TC) units control the transitions between various topologies. For instance, TC_i controls the transition behavior of the converter from the i th converting topology to the $(i + 1)$ th topology. In the transition from i th topology to the $(i + 1)$ th topology, instead of instantaneous transition from i th topology to $(i + 1)$ th topology, for α_i switching cycle, converter operates in i th topology and for β_i switching cycle, it operates in the $(i + 1)$ th topology.

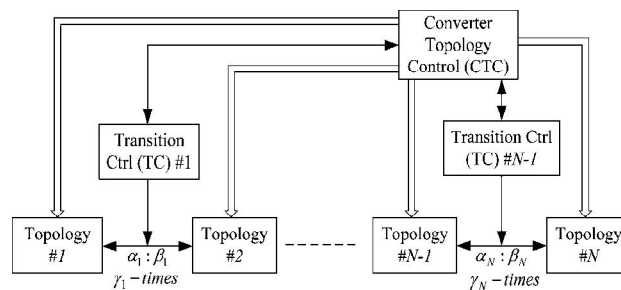

Fig. 3 Block diagram of the theory of digital combination of power converters.

Operation with α_i and β_i switching cycles in transition mode will be repeated for γ_i times. For a specific case, where $\alpha_i = m_i$, $\beta_i = 1$ and $\gamma_i = m_i - 1$, in the transition from the i th topology to the $(i + 1)$ th topology, for the m_i switching cycle, the converter operates in i th topology and for one switching cycle, it switches to the $(i + 1)$ th topology. Then, in the next cycle, TC_i tries to increase the number of cycles of operation in the $(i + 1)$ th topology and decrease the number of cycles of operation in the i th topology. Then, in the next cycle, TC_i tries to increase the number of cycles of operation in the $(i + 1)$ th topology and decrease the number of cycles of operation in the i th topology. Finally, before the complete transition to the $(i + 1)$ th topology, for one switching period, it operates in the i th topology and, for m_i switching cycle, it switches to the $(i + 1)$ th topology. DCPC imposes the fact that the proposed converter topology should have the capability of operating in various converter topologies with only controlling the switching components of the circuit.

B. OPERATION OF POSITIVE BUCK–BOOST CONVERTER

The circuit topology of a positive buck–boost converter is shown in Fig.4. In buck–boost operating mode, always, two switches, Q_1 and Q_2 , and two diodes, D_1 and D_2 , are switching in the circuit. A positive buck–boost converter can operate as a buck converter by controlling switch Q_1 and diode D_1 , when Q_2 is OFF and D_2 is conducting. It can also work as a boost converter by controlling switch Q_2 and diode D_2 , while Q_1 is ON and D_1 is not conducting. When the voltage of the battery is more than the output reference voltage, converter operates as a buck converter. As

soon as the voltage of the battery drops to a value less than the output reference voltage, the converter should switch to boost mode. The added advantage of the converter is that the output of such a converter is always positive.

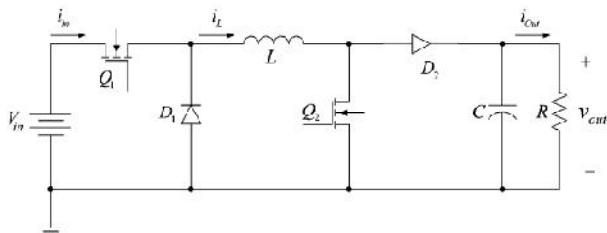

Fig.4 Circuit topology of a positive buck-boost converter.

The overall system level closed loop control strategy of the proposed method is shown in Fig.5. Here, both the input and the output voltages are sensed and the proper duty ratios are applied to the switches Q1 and Q2 based on proper duty setting and the desired mode of operation.

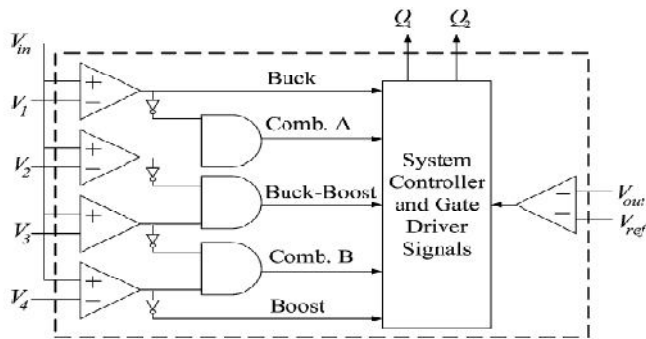

Fig. 5 Closed loop control strategy for the proposed method.

IV. SYSTEM IMPLEMENTATION

Discusses the operation of the converter in different modes and issues associated with transition from buck to boost:

The input voltage of the battery when fully charged is 6 V and when discharged is 3.6 V. This supply needs to continuously provide a steady output of 5 V. Thus, the converter needs to operate in the buck mode for the period “TA,” followed by the buck-boost

mode for “TB,” and finally in the boost mode for “TC”.

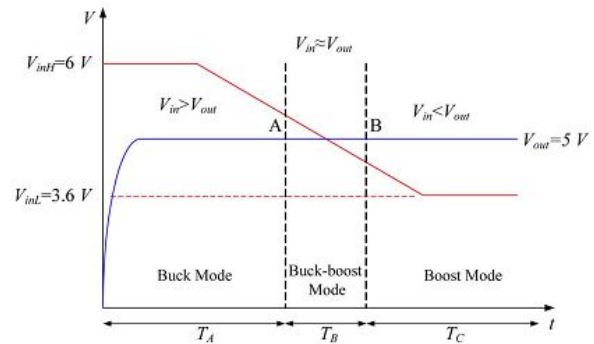

Fig 6 Input output curve for the converter

The change in the duty ratio for different modes of operation based on different ranges of the input voltage is shown in Fig. 6. Referring to Tab.1, for the period “TA,” the converter works in the buck mode, where the duty changes from the minimum value when the input is 6 V to the maximum when the input is approximately between 5.1 and 4.9 V, as shown in Fig 6; for the time “TB ,” the converter is in buck-boost mode; and, finally, for the period “TC ,” it is working in the boost mode. The points “A” and “B” in Fig.6 are in reference to those in Tab. 1.

$D_{min, buck}$	6V
$D_{max, buck A,}$	Buck Region
Buck-Boost Region	5.1V-4.9V
$D_{min, boost B,}$	Boost Region
$D_{max, boost}$	3.6V

Tab .1 Duty ratio variation for the buck and boost modes.

A. ANALYTICAL STUDIES

In buck topology, when V_{in} is equal to V_{out} , the duty cycle will approach to 1, $D_{buck} = V_{out}/V_{in}$. In the boost operating topology, when V_{in} approaches V_{out} , the duty cycle moves toward zero, $D_{boost} = 1 - (V_{in}/V_{out})$. In the buck-boost operating condition, since $D_{buck-boost}$

$= V_{out}/V_{in} + V_{out}$, therefore, for V_{in} equal to V_{out} , duty cycle becomes 0.5. In other words, when V_{in} decreases toward V_{out} , the duty cycle should follow the pattern of 1 for buck to 0.5 for boost and then zero in the boost operating topology. This is demonstrated in Fig. 7.

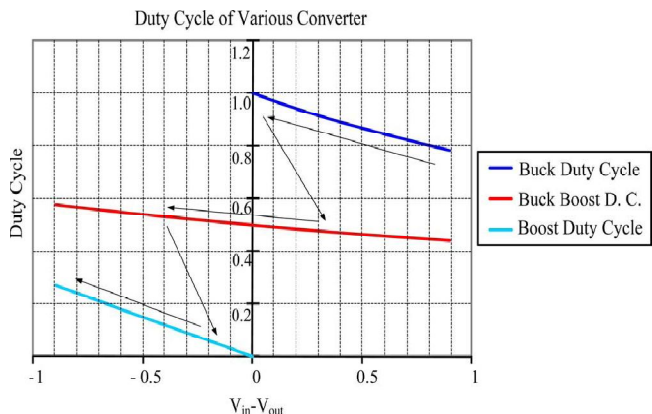

Fig. 7. Variations of duty cycle of buck, buck–boost, and boost converters versus $V_{in} - V_{out}$.

Instantaneous transition from buck to buck–boost or boost incorporates a sudden change in the duty cycle from $D_{buck,max} = 1$ to $D_{buck-boost} = 0.5$ or $D_{boost,min} = 0$. Output voltage variations are associated with the sudden changes in the duty cycle change, due to the fact that output voltage is a nonlinear function of the duty cycle.

Transition between different modes of operation is a result of comparing the output of the error amplifier (EA_{out}) and its level shifted value (VLS) with the saw tooth waveform, as shown in Fig. 7. Since during a transition from buck to buck–boost the duty cycle changes from 1 to 0.5, the EA output signal should be level shifted by $0.5 V_{pp}$. However, to prevent toggling between buck mode and buck–boost mode, the VLS should be less than $0.5 V_{pp}$. In buck mode, $D_{buck} = EA_{out} \cdot V_{in}$ approaches V_{out} , and D_{buck} approaches 1. In buck–boost mode, $D_{buck-boost} = EA_{out} - 1 + 0.5$. When V_{in} is equal to V_{out} , $D_{buck-boost}$ becomes 0.5. In boost mode, $D_{boost} = EA_{out} - 1 + \Delta$, where $\Delta = (V_{out,max} - V_{in})/V_{out,max}$ from buck–boost mode. Therefore, in each mode, the sensitivity of the control parameter EA_{out} with respect to time is $(\partial D_{buck}/\partial t) = (\partial EA_{out}/\partial t)$, $(\partial D_{buck-boost}/\partial t) = (\partial EA_{out}/\partial t)$, and $(\partial D_{boost}/\partial t) = (\partial EA_{out}/\partial t)$. Based on the relationship of the input–output voltage of the buck ($D_{buck} = V_{out}/V_{in}$), buck–boost ($[V_{out}/V_{in}] = [D_{buck-boost}/1 - D_{buck-boost}]$), and boost

($[V_{out}/V_{in}] = [1/1 - D_{boost}]$) operation topologies, we have

$$\frac{\partial(V_{out}/V_{in})}{\partial D_{buck}} \frac{\partial D_{buck}}{\partial t} = 1 \tag{1}$$

$$\frac{\partial(V_{out}/V_{in})}{\partial D_{buck-boost}} \frac{\partial D_{buck-boost}}{\partial t} = 1/(1 - D_{buck-boost})^2 \tag{2}$$

$$\frac{\partial(V_{out}/V_{in})}{\partial D_{boost}} \frac{\partial D_{boost}}{\partial t} = 1/(1 - D_{boost})^2 \tag{3}$$

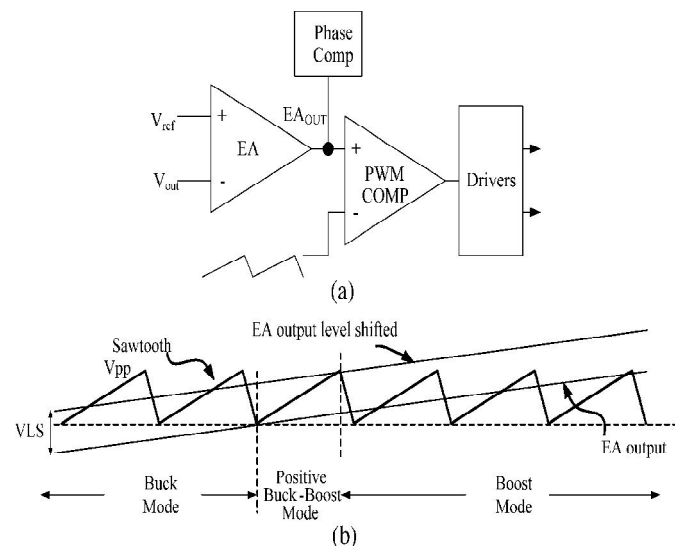

Fig. 8. General block diagram of error amplifier and drivers. (b) Operation modes.

Based on (1), output voltage of the converter in buck mode is a linear function of the duty cycle. In other words, for the case of switching frequencies higher than natural frequency of the system, the controller is able to regulate the transient in the output voltage. However, the output voltage of the converter in boost and buck–boost modes is a nonlinear function of the duty cycle, based on (2) and (3). This means that the direct transition from buck to buck–boost or boost will incorporate output voltage variations, which cannot be well regulated by conventional control techniques.

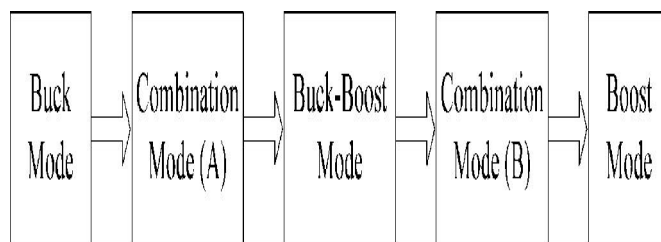

Fig. 9. Combined-method-based control logic for deciding modes of operation.

V. HARDWARE DIAGRAM

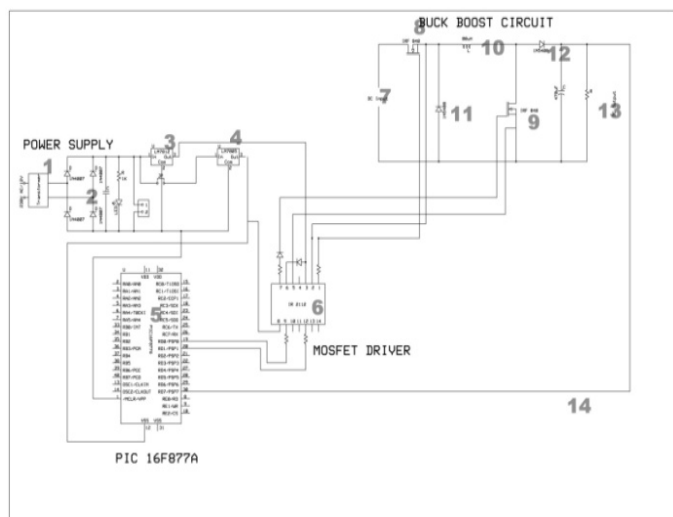

Fig 10 Hardware diagram

- 1- Transformer (230/12 V)
- 2- Rectifier
- 3,4- Voltage regulators(LM 7805,12)
- 5-Micro controller (16F877A)
- 6-Gate driver (IR 2110)
- 7-DC supply (5v)
- 8,9- MOSFET (IRF840)
- 10- Inductor (80 mH)
- 11,12- Diode (IN5408)
- 13- Capacitor(470 μ F)
- 14- Feed back loop

HARDWARE USED

- Mosfet \rightarrow IRF840
- PIC Microcontroller \rightarrow 16F877A
- Gate Driver \rightarrow IR2110
- Diode \rightarrow IN5408

VI. SIMULATION RESULTS

The simulation results have been obtained for the converter based on the parameters shown in Table 2.

PARAMETERS OF POSITIVE BUCK-BOOST CONVERTER

Variable	Parameter	Value
L	Magnetizing Inductance	100 μ H
C	Output Filter Capacitance	330 μ F
V_{in}	Input Voltage	3.6-6 V
V_{ref}	Output Voltage	5 v
f	Switching Frequency	100 KHz
R	Output Resistance	20 Ω

Table 2 parameters of positive buck-boost converter

A. CONVENTIONAL METHOD OF SOLVING THE TRANSITION PROBLEM

Simulations are carried out on the positive buck-boost converter using the conventional methods. Fig.5.1 presents the output voltage waveform, buck and boost pulses for a direct transition from buck to boost mode. There is about 12% 14% ripple in the output voltage during direct transition from buck to boost. Fig. shows the output voltage, input voltage, and buck and boost pulses for a transition from buck to boost with an intermediate buck-boost mode. In this method, the converter initially works in the buck mode, when the input voltage is greater than the output voltage, followed by the buck-boost mode when the voltages are almost equal. Finally, the converter works in the boost mode when the input voltage is lower than the output voltage. The simulation results indicate that the presence of spikes in the output voltages during transitions through different modes is about 6%.

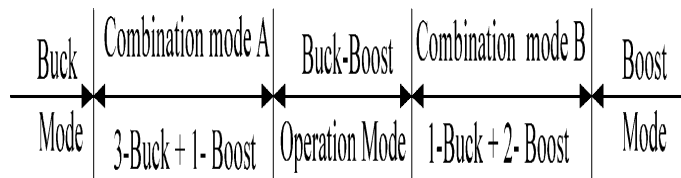

Fig 11. Transition diagram

B. SIMULATION DIAGRAM

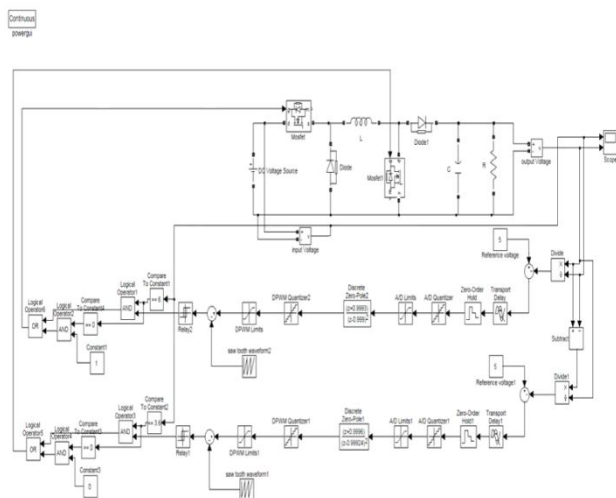

Fig 12 Simulation Block

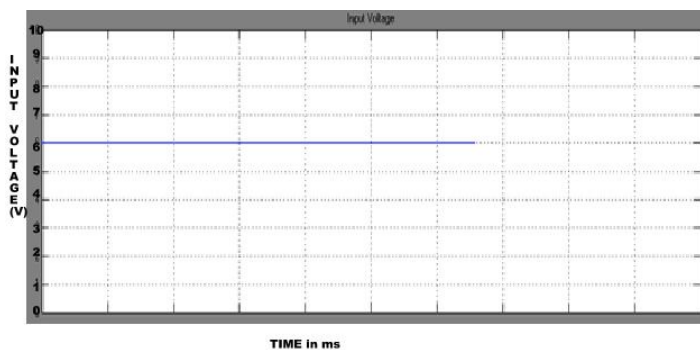

Fig 13. Input voltage during buck operation

The above diagram shows the input voltage given to the converter to check the buck operation since the output is 6v, it has to reduce the output voltage to 5.

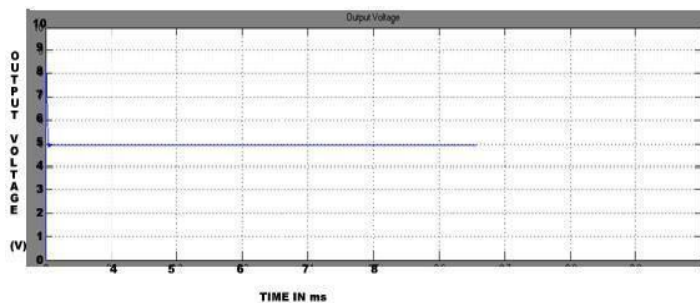

Fig 14 Output voltage of the converter during buck operation

The above diagram shows the voltage has been reduced from 6 to 5 v

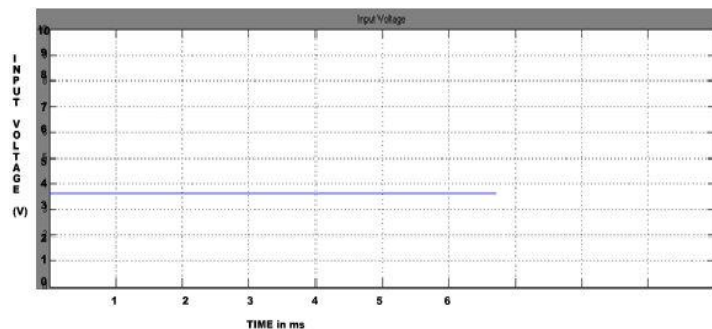

Fig 15. input voltage waveform for during boost operation

The above diagram shows the input voltage to check the boost operation of the converter. Here the input is set to 3.6v, the output should be 5 v.

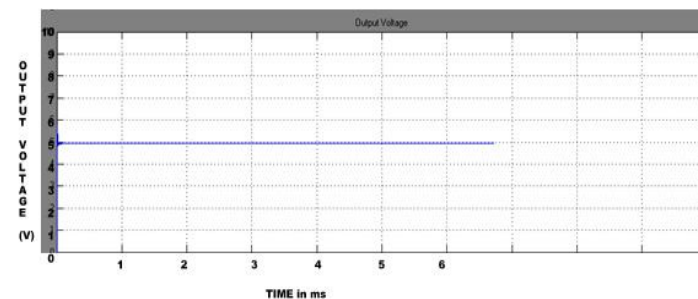

Fig 16 output voltage for boost operation

From the above diagram it is seen that the output voltage is 5 v.

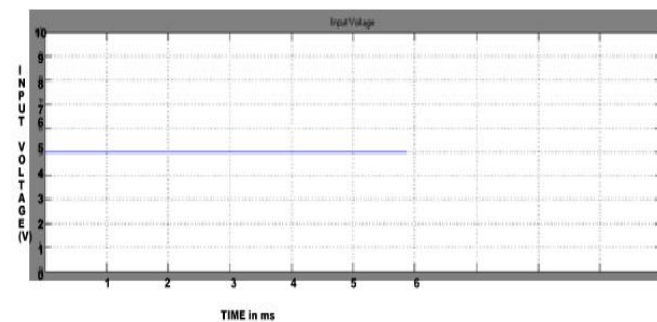

Fig 17. Input voltage waveform for during buck-boost operation

The above figure shows the input voltage to check buck-boost operation

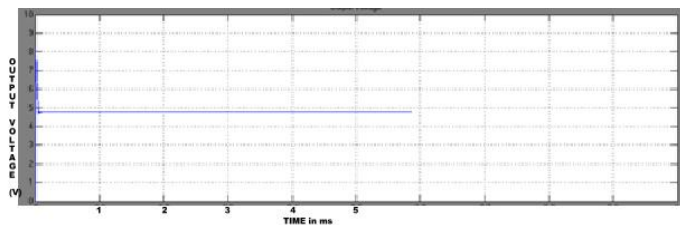

Fig 18 Output voltage during buck-boost operation

As we see from the above figure the output voltage is 5 V

The above results were obtained during the simulations.

4.2.1 FOR OBSERVING RIPPLES FROM TRANSITION FROM ONE MODE TO ANOTHER

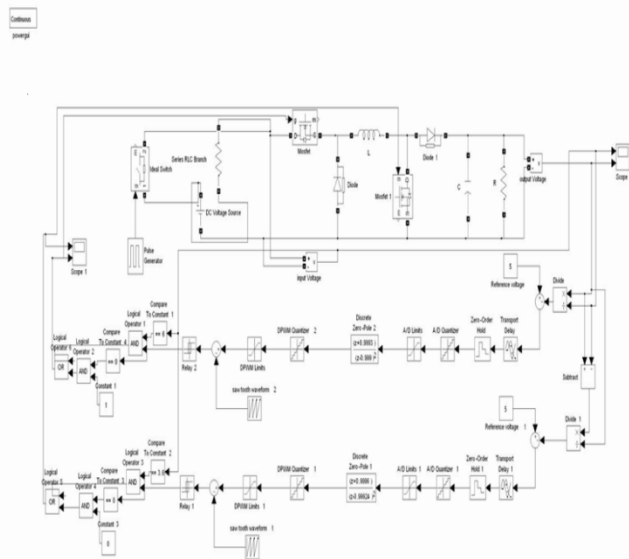

Fig 19 simulation block for transition from one mode to another

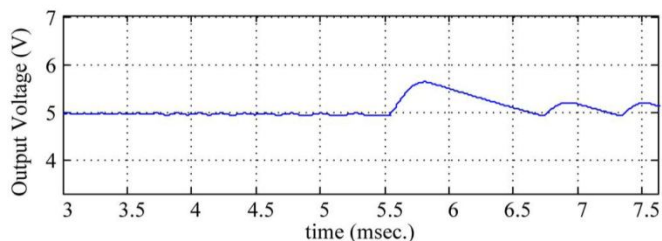

Fig 20 Simulated output voltage for a transition from Buck → Boost mode

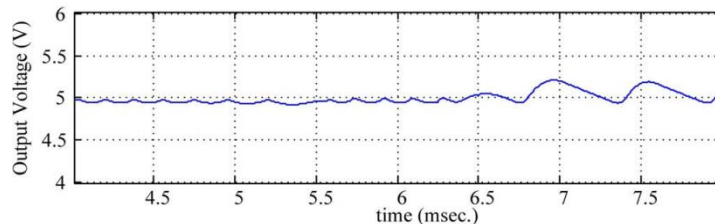

Fig 21 Output voltage for transition from Buck → Buck-Boost → Boost

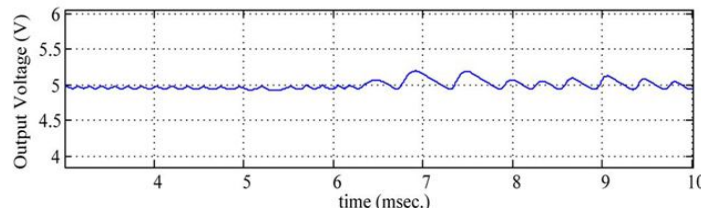

Fig 22 Output voltage for transition from Buck → Comb A → Buck-Boost → Comb B → Boost

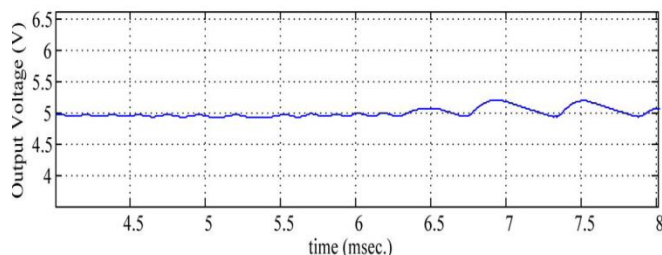

Fig 23 Output voltage from Buck → Comb A → Comb B → Boost

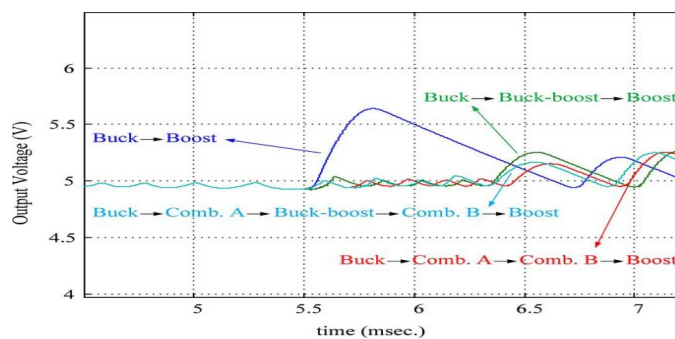

Fig 24. Comparison of output voltage for all four different transient modes

Transition	Output ripple (%)
Direct Buck to Boost	12%
Buck to Buck-Boost	4%
Buck-Boost to Boost	6%
Buck to Combination mode A	<3%
Combination mode A to Buck-Boost	<2%
Buck-Boost to Combination mode B	<2%
Combination mode B to Boost	<3%
Combination mode A to Combination mode B	<2%

Tab 3. Summary of the output voltage transients during transition from different modes of operation

As seen from the Tab 3 it is better to choose the transition Buck \rightarrow CombA \rightarrow Buck-Boost \rightarrow Comb B \rightarrow Boost. Though the transition Buck \rightarrow CombA \rightarrow CombB \rightarrow Boost yields the same results. Then the efficiency of the transitions are taken in account. From our reference in some ieee papers we choose Buck \rightarrow CombA \rightarrow Buck-Boost \rightarrow CombB \rightarrow Boost transition .

VII. RESULTS AND CONCLUSIONS



Fig 25 Output voltage seen in CRO

For all the voltages between 3.6 - 7 v the output is around 5v. As the transitions takes place in fractions of seconds we are not able to cap true it.

5.2 CONCLUSIONS

A highly efficient control strategy to control a pulsewidth modulation (PWM) dc/dc positive buck–boost switching converter has been illustrated in this paper. The proposed control scheme can regulate the output voltage for an input voltage, which changes based on the charge status of the battery supply. The technique introduced in this paper is unique of its kind in improving the efficiency and the ripple content of the output voltage for a positive buck–boost converter whenever smooth transition is needed from the buck mode to the boost mode. In addition, the concept of DCPC is introduced, which improves the transition ripple by distributing the voltage transients.

In this method, the capability of skipping over higher loss interface stages such as buck–boost mode in the case of a positive buck–boost converter significantly improves the efficiency of the circuit topology. The presented simulations and experimental results validate the proposed theory and its merits. In this manuscript, the proposed theory has been utilized to improve the output voltage transients in transition from buck to boost mode. This is an enabling technology to improve voltage transients in any applications that require transition between different converter topologies.

REFERENCES

- [1] A. Chakraborty, A. Khaligh, A. Emadi, and A. Pfaelzer, “Digital combination of buck and boost converters to control a positive buck–boost converter,” in Proc. IEEE Power Electron. Spec. Conf., Jun. 2006, vol. 1, pp. 1–6.
- [2] A. Chakraborty, A. Khaligh, and A. Emadi, “Combination of buck and boost modes to minimize transients in the output of a positive buck–boost converter,” in Proc. IEEE 32nd Ind. Electron. Annu. Conf., Paris, France, Nov. 2006, pp. 2372–2377.
- [3] R.W.Erickson, Fundamentals of Power Electronics, 4th ed. Norwell, MA: Kluwer, 1999.
- [4] Y. Konishi and Y. F. Huang, “Soft-switching buck boost converter using pulse current regenerative

resonant snubber,” *Electron. Lett.*, vol. 43, pp. 127–128, Jan. 2007.

[5] L. S. Yang, T. J. Liang, and J. F. Chen, “Analysis and design of a novel three phase AC–DC buck–boost converter,” *IEEE Trans. Power Electron.*, vol. 23, no. 2, pp. 707–714, Mar. 2008.

[6] B. Sahu and G. A. Rincon-Mora, “A low voltage, dynamic, noninverting, synchronous buck–boost converter for portable applications,” *IEEE Trans. Power Electron.*, vol. 19, no. 2, pp. 443–452, Mar. 2004.

[7] B. Bryant and M. K. Kazimierzuk, “Derivation of the buck–boost PWM DC–DC converter circuit topology,” in *Proc. Int. Symp. Circuits Syst.*, May 2002, vol. 5, pp. 841–844.

[8] Y. Zhang and P. C. Sen, “A new soft-switching technique for buck, boost, and buck–boost converters,” *IEEE Trans. Ind. Appl.*, vol. 39, no. 6, pp. 1775–1782, Nov./Dec. 2003.

[9] C. Jingquan, D. Maksimovic, and R. Erickson, “Buck–boost PWM converters having two independently controlled switches,” in *Proc. IEEE 32nd Power Electron. Spec. Conf.*, Jun. 2001, vol. 2, pp. 736–741.

[10] D. Adar, G. Rahav, and S. Ben-Yaakov, “A unified behavioral average model of SEPIC converters with coupled inductors,” in *Proc. IEEE Power Electron. Spec. Conf.*, Jun. 1997, vol. 1, pp. 441–446.