



Multi Agent Approach for Environmental Customer Collaboration

Mohamed Dif El Idrissi¹, Abdelkabar Charkaoui², Abdelwahed Echchatbi³

¹Mechanical, Industrial Management And Innovation Laboratory, Faculty Of Sciences And Technologies University Hassan First, Settat, Morocco, M.Difelidrisi@gmail.com.

²Mechanical, Industrial Management And Innovation Laboratory, Faculty Of Sciences And Technologies University Hassan First, Settat, Morocco, Charkaoui.A@gmail.com.

³Mechanical, Industrial Management And Innovation Laboratory, Faculty Of Sciences And Technologies University Hassan First, Settat, Morocco, Echchatbi@gmail.com

ABSTRACT

Customer collaboration in the Green Supply Chain decisions has gained more attention among researchers and industrial practitioners. Many studies highlight that organizations can achieve a good environmental performance by considering customer collaboration and environmental regulation. To implement these two elements, the literature in Green Supply Chain Management (GSCM) suggests having a structured information exchange process and proper communication between supply chain partners. For this reason, a multi agent system (MAS) approach is proposed to facilitate the customer collaboration process. This research shows that MAS can be utilized to reduce the complexity and facilitate communications in greening the Supply Chain.

Keywords : Supply Chain, Green Supply Chain Management, Multi Agent Systems, Customer Collaboration, environmental regulation.

1. INTRODUCTION

With increasing attention from customers, stakeholders, government legislations, and environmental organizations, companies are driven to consider environmental impacts of their activities. As a result, all these external and internal calls have led companies to integrate the "Green" concept into their Supply Chain [1]. The environmental customer collaboration has been defined as an important Green Supply Chain practice which can improve the organizations performance [2]. In fact, the environmental performance can be improved if organizations collaborate more with upstream suppliers and downstream customers [3]. On the other hand, environmental regulation is also a parameter which can influence the Green Supply Chain decisions. Many factors such as product pricing, import duty, tax and environmental regulation should be considered in Green Supply Chain strategies [4]. Besides, few studies have combined the customer collaboration and the environmental regulations in their model. Therefore, this study attempts to

fill in this gap in the literature by proposing a multi agent structure to improve customer collaboration with a delivery allocation sub-model, which include environmental regulations.

This paper is organized as follows. Section 2 describe the problem statement and also the research design. Section 3 presents the proposed MAS approach and its constituents. The computational element in the MAS approach is the delivery allocation model which is described in Section 4. Finally, a conclusion and perspectives for future work are presented in Section 5.

2. PROBLEM STATEMENT

There are many studies, which highlight the role of customer collaboration in GSCM. Indeed, many researchers identified cooperation of customers with eco-design, cleaner production, and using less energy during product transportation and green design as an important variable [5],[6]. Therefore, organizations need to make interactions with customers in order to improve the environmental supply chain performance [7]. However many researchers highlight that there a still a lack of studies in the literature that investigates GSCM based on the viewpoint of partners associated with a supply chain network, which include suppliers, customers, logistics and manufacturer point of view[8]. For this reason, researchers ask for more investigation in terms of greening efforts between Supply Chain partners with reference to collaboration and incentives [9]. Also they consider that the government policies and industrial regulations in different countries could influence the success of collaboration and incentive levels and it needs to be incorporated in the future studies of green supply chain management [10].

In the literature review conducted by Jain, Wadhwa, and Deshmukh (2009) [11], it was indicated that that use of advanced communication technology can be very useful for Supply Chain collaboration and integration. Wei, Wong, and Lai (2012) [12] concluded that information technology (IT) based exchange relationship and information

integration can improve the performance in a Supply Chain. For this reason, multi agent systems can be used to improve the collaboration and also information exchange between Supply Chain partners. A MAS can be defined as a system of multiple agents that can work and interact collectively to solve problems that would be beyond their individual capabilities [13]. Ghadimi, Toosi and Heavey (2018) [14] provide structured information exchange processes to make better sustainable procurement decisions by maintaining a long-term partnership between the manufacturer and its suppliers. They concluded that MAS is able to reduce communication and information exchange problems in the sustainable suppliers selection process. Mishra, Kumar and Chan (2012) [15] propose to Solve the complexity of including waste management and recycling in the GSCM by using MAS structure. Giret and Salido (2017) [16] Propose an approach to implement a reverse manufacturing process following a service-oriented manufacturing paradigm through a virtual market supported by intelligent software agents.

To our knowledge, none of the above works considered the customer collaboration and the environmental regulations in their model. Besides, there is no research study that investigates the applicability and suitability of the MASs on this problem in enhancing the communication and information exchange components between supply chain partners specifically for the environmental customer collaboration. The issues and requirements in the other dyadic relationships of the supply chain such as manufacturer-retailer can also be studied and investigated [14]. The primary contribution of this work is to develop a MAS approach for GSCM implementation including customer collaboration and environmental regulations in order to provide better communication and structured information exchange processes which helps the industrial practitioners and decision-makers inside manufacturing organizations to make better sustainable distribution decisions.

3. MAS STRUCTURE

3.1 Agents definition

The delivery process for a three echelon Supply Chain can be seen as a network of three layers such as manufacturer, distributor and customer.. These three downstream members of the Supply Chain should collaborate together to make a sustainable delivery decision. The manufacturing company is the seller in this process and its customer is the distributor, which is the seller for many customers. In this study, we consider one manufacturer, one distributor and many customers. In the suggested MAS structure, seven types of agents are identified: Customer Agents CA, Delivery Allocation Agent DAA2 (Distributor), Database Agent DBA1 (Distributor), Distribution Agent DA, Delivery Allocation DAA1 (Manufacturer), Database Agent DBA2 (Manufacturer) and Manufacturer Agent MA. The figure 2 illustrates the defined agents.

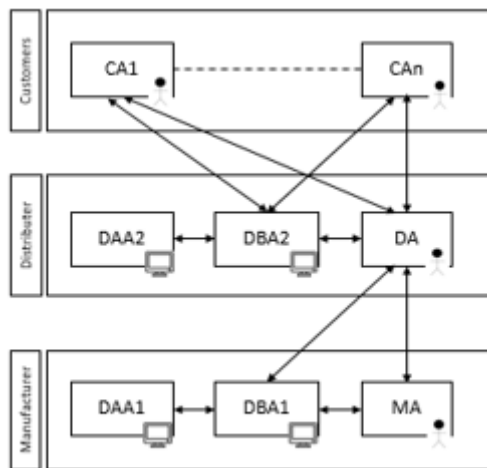

Figure 1 : The proposed MAS structure

For illustration purposes, we will focus on the dyadic relationship between the distributor and customers. Each agent has some specific functions and responsibilities in this process. Table 1 illustrates the defined agent with their respective responsibilities :

Table 1 : Agents responsibilities

Agent	Responsibility
CA	1. Send orders confirmation to DBA2
	2. Receive a confirmation from the DBA2 that the orders are received.
	3. Receive delivery allocation result from DA
	4. Send delivery confirmation to DA
DAA2	1. Request delivery allocation data from DBA
	2. Receive delivery allocation data from DBA
	3. Calculates the optimal delivery quantities using the mathematical delivery allocation model
	4. Request the delivery quantities to be saved to in the database by DBA.
	5. Receive the CA confirmation to proceed with the delivery
DBA2	1. Receive orders confirmations from CA
	2. Save orders confirmation from CA in the database
	3. Inform the CA that the orders are saved.
	4. Receive delivery allocation data request from DAA
	5. Send delivery allocation data to DAA
	6. Receive the delivery quantities and save them in the database
DA	1. Request delivery allocation result from DAA2
	1. Receive delivery allocation result from DAA2
	2. Inform and negotiate the delivery allocation result with CA
	3. Receive CA confirmation and proceed with delivery

3.2 Communication and interaction between agents

The success of a multi-agent architecture depends on effective communication between agents using a certain Agent Communication Language (ACL) to interpret and manipulate unexpected changes and actions to take. An agent communication language is a language whose syntax, semantics and pragmatics are precisely defined. Agent Communication Language (ACL) messages can be based on the FIPA Agent communication specifications. In addition, MAS interactions can be achieved using the FIPA Semantic Language (SL) content language, which is a string-coded content language. In this step of MAS design, the agents interaction analysis is done using the FIPA interactions protocols based on the defined responsibilities of each agent. Table 2 shows these interactions:

Table 2 : Agents interactions

Agent	Interaction	Role	Protocol	With
CA	Send orders confirmation to DBA	1	FIPA request	DBA
CA	Send delivery confirmation to DA	4	FIPA request	DAA
DAA2	Request delivery allocation data from DBA	2	FIPA request	DBA
DAA2	Request the delivery quantities to be saved to in the database by DBA	4	FIPA request	DBA
DBA	Inform the CA that the orders are saved.	3	FIPA inform	CA
DBA	Send delivery allocation data to DAA	5	FIPA inform	DAA2
DA	Request delivery allocation result from DAA2	1	FIPA request	DAA2
DA	Inform and negotiate the delivery allocation result with CA	2	FIPA inform	CA

Based on the agent interactions, 2 types of FIPA interaction protocols are defined: FIPA inform and FIPA request. These interactions structure is implementable on the JADE platform.

4. COMPUTATIONAL ELEMENTS IN THE PROPOSED MAS APPROACH

In this section, the delivery allocation model of the developed MAS approach is explained. This mathematical model is used as the internal behavior activity of the DAA2 incorporating both financial and environmental indicators. In fact, total delivery cost measure to account for all financial expenses related to the delivery of products and

environmental cost is evaluated based on the environmental taxation as well as the total emission of CO₂ for a given transportation mode. Since two Supply Chain performance indicators are used in the modeling approach, a multi objective optimization is implemented to construct this model as there is a few number of approaches combining financial and environmental issues in multi objective frameworks to address the supply chain design problem [17]. The outcome of this model will allow a company to determine the optimal delivery quantities to the customers, select the most appropriate transportation mode to move the products and measure CO₂ emissions related to the delivery process. Therefore, useful information will be provided to the decision maker, allowing for better analysis and creating more sustainable decisions.

The description of the proposed model is explained in three sub-sections namely problem definition, model elements, model formulation.

4.1 Problem definition

The proposed model is composed of two main echelons namely manufacturer warehouses and customer locations in which the connection between echelons is depicted in Figure 3. A single product is considered and there are several transportation modes (i.e. road,rail, etc). below are the assumptions stated to establish this model :

- Demand of all customers is known and deterministic;
- Every customer demand is always satisfied by any manufacturer warehouse.
- Several transportation alternatives are available;
- One product which is defect free;
- Distance between network nodes (used for CO₂ emissions evaluation) are assumed to be given by the straight path between facilities;
- The unit transportation costs is predefined

4.2 Model elements

Considering the described problem, the model is composed of sets, parameters and variables listed below.

- Sets:

I : manufacturer warehouses indexed by i

J: customer locations indexed by j

K : transportation modes indexed by k

- Parameters :

C_{ijk} : the unit transportation costs between manufacturer warehouse i and customer location j using transportation mode k (Eur/Ton)

Θ_{ijk} : the distance between manufacturer warehouse i and customer location j (Km)

CS_i : the storage costs at the warehouse i (Eur/Ton)

Q_i : the storage capacity of warehouse i (Tons/Year)

B_m : the unit CO₂ emission using transportation mode m (Tons/Ton.Km)

Γ : Environmental taxes(Eur/Ton)

Q_{ijk} : the transportation capacity between manufacturer warehouse i and customer location j using transportation mode k (Tons)

D_j : the demand of product of the costumer j (Tons)

- Variables :

q_{ijk} : the amount of product shipped from the manufacturer warehouse i to the customer location j using the transportation mode k (Tons)

4.3 Model formulation

The formulation of the proposed model is divided into two parts, objective function and constraints. The model has two objectives, the first one is to minimize total delivery cost (DC) which is the summation of transportation cost (TC) and storage cost (SC), and the second is to minimize the environmental cost (EC) which is measured based on the environmental taxation and the CO2 emissions related to the delivery process. it is assumed that the total emission of CO2 is due to transportation. The mathematical formulation of the objective function is described in Eqs. 1-4.

$$Minf = DC + EC = TC + SC + EC \quad (1)$$

$$SC = \sum_{i,j,k} CS_i \cdot q_{ijk} \quad (2)$$

$$TC = \sum_{i,j,k} C_{ijk} \cdot q_{ijk} \quad (3)$$

$$EC = \gamma \cdot \sum_{i,j,k} \theta_{ijk} \cdot B_k \cdot q_{ijk} \quad (4)$$

The constraints of the mathematical model are given in Eqs. 5-8.

Total quantity of product shipped from any manufacturer warehouse to customer location through any transportation mode should be equal to total customer demand.

$$\sum_{i,k} q_{ijk} = D_j \forall j \in J \quad (5)$$

Total quantity of product shipped from any manufacturer warehouse to customer location through any transportation mode should be lower or equal to the warehouse capacity.

$$\sum_{j,k} q_{ijk} \leq Q_i \forall i \in I \quad (6)$$

Total quantity of product shipped from any manufacturer warehouse to customer location through any transportation mode should be lower or equal to the transportation capacity.

$$q_{ijk} \leq Q_{ijk} \forall i \in I, \forall j \in J, \forall k \in K \quad (7)$$

Total quantity of product shipped from any manufacturer warehouse to customer location through any transportation mode should be lower positive.

$$q_{ijk} \geq 0 \forall i \in I, \forall j \in J, \forall k \in K \quad (8)$$

5. WORKFLOW OF THE PROPOSED MULTI AGENT SYSTEM

The individual tasks of the defined agents are already described in the previous section. The execution process starts with an order confirmation from the customer side, which needs to be sent to the Database agent of the distributor for saving in internal system. Then, a notification should be sent to the delivery allocation agent, which run an algorithm to evaluate the best shipment decision from both financial and environmental perspective based on customer requirements (order, requested delivery time, location ...), distributor constraints (product availability, transportation mode availability ...) and environmental impact (CO2 emissions, environmental taxes ...). The result out of this algorithm needs to be sent to the

distributor agent in order to start the negotiation with the customer about the possible scenarios to ship him the goods. The below illustrate the workflow of the proposed multi agent system:

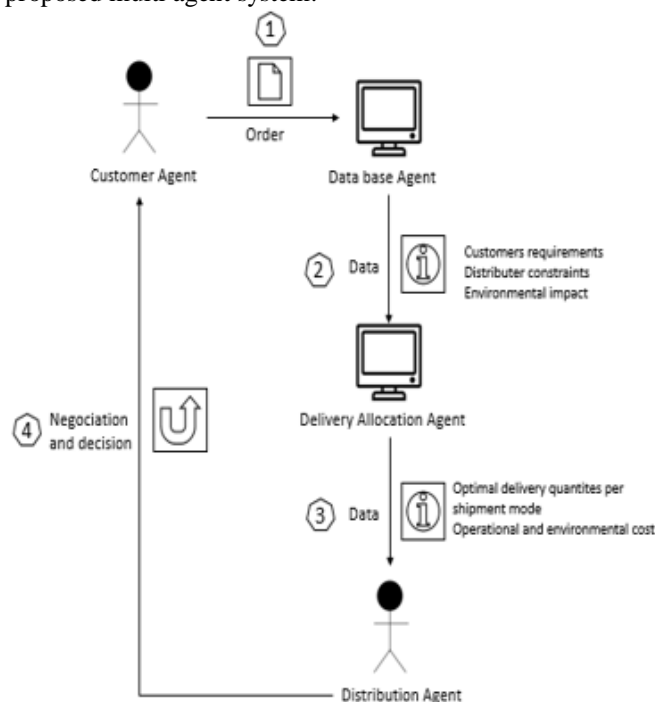

Figure 2 : Workflow of the proposed MAS structure

6. SUMMARY AND DISCUSSION

The environmental issues have attracted the attention of many researchers in last years who precise that the implementation of Green Supply Chain is very complex and needs to be done in a more collaborative way together with the other Supply Chain partners. Following the same direction, this paper address particularly the issues related to the customers environmental collaboration taking into account also the environmental regulations. The aim is to design a framework, which can help Supply Chain partners to make more sustainable decisions through a multi agent system for a three echelon Supply Chain composed of manufacturers, distributors and customers. The proposed system studies first the dyadic relationship between one manufacturer and many customers and consists of many autonomous agents responsible for handling specific tasks in the green supply chain. The communication channel is ensured using the ACL language based on two main protocols defined by FIPA such as; FIPA inform and FIPA request. The autonomous decision-making by the delivery allocation agent is based on mathematical algorithm, which provides a negotiation basis with customers about the most environmental delivery decision. Moreover, This framework can be extended by adding other Supply Chain partners or reconfigured according to industry specific requirements. Therefore, the proposed framework can assist Supply Chain managers to effectively make sustainable decision with their customers.

7. CONCLUSION AND FUTURE WORK

In this paper, a MAS approach for an environmental customer collaboration process was presented. The goal of the proposed approach is to facilitate the information exchange between supply chain partners for the GSCM implementation by providing an easy framework based on interactive agents which can collectively solve problems beyond their individual capabilities. The proposed framework design the relationship between manufacturer-customer through the definition of many different agents, the identification of eventual responsibilities and interactions between the agents, and finally the mathematical delivery allocation model based on multi objective programming which is the internal behavior of the delivery allocation agent. The framework is currently under development in order to determine the optimal delivery solution and to perform validation test. Moreover, the authors are interested to enhance the work by conducting a comprehensive experiment adopted from a real case scenario to confirm the applicability and suitability of MAS approach in GSCM problems.

REFERENCES

1. Zhu, Q., Sarkis, J., and Lai, KH. Examining the Effects of Green Supply Chain Management Practices and Their Mediations on Performance Improvements, *International Journal of Production Research*, vol. 50, pp. 1377-1394, 2012.
<https://doi.org/10.1080/00207543.2011.571937>
2. Zhu, Q., Sarkis, J., and Lai, KH. Green supply chain management: Pressures, practices and performance within the Chinese automobile industry, *Journal of Cleaner Production*, vol. 15, no.11, pp. 1041-1052, 2007.
3. Vachon, S., Klassen, RD. Environmental management and manufacturing performance: the role of collaboration in the supply chain. *International Journal of Production Economics*, vol.111, no. 2, pp.295–308,2008.
4. Khan, SAR., Dong, QL., Yu, Z. Research on the measuring performance of green supply chain management: In the perspective of China. *International Journal of Engineering Research in Africa*, vol. 27, pp.167-178, 2016.
5. Yu, W., Ramanathan, R., Nath, P. The impacts of marketing and operations capabilities on financial performance in the UK retail sector: a resource-based perspective. *Industrial Marketing Management*, vol. 43, no.1, pp.25–31, 2014.
6. Angappa G., Nachiappan S., Shams R. Green supply chain collaboration and incentives: Current trends and future directions, *Transportation Research Part E: Logistics and Transportation Review*, vol.74, pp.1-10,2015.
<https://doi.org/10.1016/j.tre.2015.01.002>
7. Green, KW., Zelbst, PJ., Meacham, J., Bhadauria, VS. Green supply chain management practices: impact on performance. *Supply Chain Management: An International Journal*, vol. 17, no.3, pp. 290–305,2012.
8. Carter, C.R. and Ellram, L.M. Reverse Logistics: A review of the literature and framework for future investigation, *Journal of Business Logistics*, vol. 19, no. 1, pp. 85-102, 1998.
9. Islam, Md. S. (2019). A literature review on green supply chain management: Trends and future challenges. *Resources Conservation and Recycling*, vol.141, pp. 145-162, 2019.
10. Eltayeb, TK., Zailani, S., Ramayah, T. Green supply chain initiatives among certified companies in Malaysia and environmental sustainability: investigating the outcomes. *Resource, Conservation and Recycling*, vol. 55, no.5, pp. 495-506,2011.
11. Jain, V., Wadhwa, S. and Deshmukh, SG. Select supplier-related issues in modelling a dynamic supply chain: Potential, challenges and direction for future research. *International Journal of Production Research*, vol. 47, pp. 3013-3039, 2009.
<https://doi.org/10.1080/00207540701769958>
12. Wei, H.L., Wong, C.W., Lai, KH. Linking inter-organizational trust with logistics information integration and partner cooperation under environmental uncertainty, *International Journal of Production Economics*, vol. 139, pp. 642-653, 2012.
13. G.M. O'Hare, N. Jennings, *Foundations of distributed artificial intelligence*, John Wiley & Sons, 1996.
14. Ghadimi, P., Ghassemi, T.F., and Heavey, C. A Multi-Agent Systems Approach for Sustainable Supplier Selection and Order Allocation in a Partnership Supply Chain. *European Journal of Operational Research*, vol. 269, no.1, pp. 286-301, 2017.
15. Mishra, N., Kumar, V. and FTS, C. A Multi-Agent Architecture for Reverse Logistics in Green Supply Chain. *International Journal of Production Research*, vol. 50, pp. 2396-2406, 2012.
16. Giret, A., Trentesaux, D., Salido, M., Garcia, E. and Adam, E. (2017). A holonic multi-agent methodology to design sustainable intelligent manufacturing control systems. *Journal of Cleaner Production*. 2017.
<https://doi.org/10.1016/j.jclepro.2017.03.079>
17. Wang, F., Lai, X., Shi, N. A multi-objective optimization for green supply chain network design. *Decis. Support Syst.* Vol. 51, no. 2, pp. 262–269, 2011.
<https://doi.org/10.1016/j.dss.2010.11.020>