



DART Wear: Danger Alert Reassuring Track Wear

Arya Nair ¹, Arya Rajagopal ², Betsy Biju ³, Clara C.J ⁴
Jinu P Sainudeen ⁵

¹Mangalam College of Engineering, Kottayam, India, nair.arya10@gmail.com

²Mangalam College of Engineering, Kottayam, India, aryaayra1998@gmail.com

³Mangalam College of Engineering, Kottayam, India, betsybiju21@gmail.com

⁴Mangalam College of Engineering, Kottayam, India, 07claru@gmail.com

⁵Mangalam College of Engineering, Kottayam, India, jinu.sainudeen@mangalam.in

ABSTRACT

Women safety is a most debated issue in our society in time, as it is termed as a major concern. There are many cases of women harassment, rape and molestation making women life difficult. In concern to this we are proposing a wearable device for women safety. The smart band concentrates on sending alert messages to ICE contacts using GPS. The smart band is being activated by double tapping on the screen. Different sensors are being used such as pulse rate sensor, temperature sensor and force sensor. Piezo-buzzer siren is also used in this system.

Key words : GPS Location, Piezo-buzzer siren, GSM module, Force sensor, Pulse rate sensor, Temperature sensor.

1. INTRODUCTION

DART wear is a women safety device which is being activated by double tapping on the screen. This is mainly based on IOT (internet of things).^[1] Network of physical devices, vehicles, and other items embedded with electronics, software, sensors, actuators, and network connectivity which define IoT and enable these objects to collect and exchange data. We have made use of this new technology in our research in such a way that it helps the women or a girl while she is in trouble. The smart band is being activated by double tapping on the screen. Piezo-buzzer siren is used within a range that can be heard from a long distance. The band consists of micro usb charging and an app is being developed that connect with a device via Bluetooth. The device send location with an interval of 5 min until turned off. The prototype is a combination of both which makes it special. Mainly used hardware's are Arduino, Bluetooth Device, Buzzer, Force sensor, Pulse rate sensor, Temperature sensor and software's are Anaconda for python, Android studio. There are many mobile applications used for women safety purpose.

2. RELATED WORKS

These are some of existing products and applications:

- Foot wear chip^[5] - One recent research study shows that there is a footwear chip which is stucked to the footwear that gets activated when the person taps one leg behind the other 4 times. It contains a chip that was stucked to the footwear and it mainly used to send the alerts.
- ROAR (Athena)^[2] - Athena is a personal safety device which Connect your smartphone via Bluetooth and add your contacts. It Press once then hold it for the sound. It makes a high frequency alarm at the same time it alert the contacts with your location in case of emergency. Press three times to silently send a distress signal to your chosen contacts. This design clips wherever you need it like your leggings, keychain, shirt or jeans.
- Raksha^[3] - women safety alert - this is an app contains a button which will send alerts to the contact that you are saved. The alert helps to see the location of the person. The phone is off then can't operate the app but using volume button we can able send alert.
- VithU:VGumrah Initiative^[4] - it is a mobile Application which is an initiative of STAR India Pvt. Ltd. provides one click at the power button of user's smartphone 2 times consecutively begins sending out alert messages every 2 minutes to their contacts that they feed into the app as the designated receivers or guardians.
- Shake2Safety^[6] - it can be used by shake their smartphone or just press the power button four times to send an SOS text or call to the registered numbers.

Most research showed up with the smart band that was used to generate the SOS signals along with the personal health information and based on that the alert was generated^[7] All the devices were used to detect health problems and ensure women safety and accordingly, the alerts were sent to the contacts feeded.

3. PROPOSED SYSTEM

We are developing a smart device that can be worn by any individual on their wrists. The band gets active when the victim double taps on the screen^[8] The device consists of pulse rate sensor that sense pulse rates of the person and a temperature sensor that sense body temperature of the person. It also consists of piezo buzzer that produces beepsoundafter 1min. The buzzer covers a range of 50 m. When the attacker tries to remove or throw it, force sensor will start and buzzer start ringing and location will be send using GPS. On the top of the band there are two nodes that emit electric current when it comes in contact with any surface and a shock will be generated. The device and the smart phone are being connected using Bluetooth for data sharing.

Proposed design consists of the modules;

- Arduino
- Bluetooth module
- Relay
- Buzzer
- GPS and GSM module
- Electric shock

Architecture diagram is shown below:

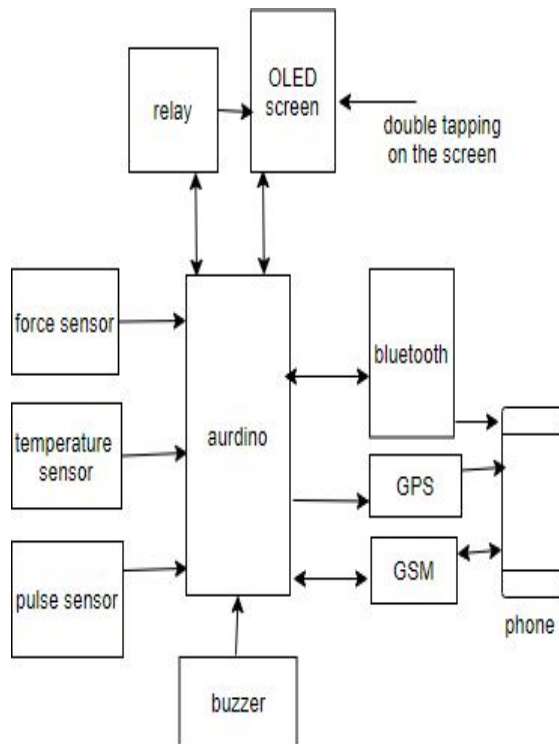

3.1 ARDUINO

Ardino is a source for ease of using hardware and software. Ardino board reads the input in the form touch the button, twitter message etc.^[10] and generates the output in the form of activating a monitor, turning on a LED etc. We can send set of instructions to microcontroller to do a task of the board. It is a tool that allows computer to sense and control physical world than desktop. Power consumption of ardino is through battery. It consists of 14 digital input/output, 6 analog inputs, a ceramic resonator, a USB connection, a power jack, an ICSP header, and a reset button. it reads the inputs and produce corresponding outputs.



3.2 BLUETOOTH MODULE

Bluetooth helps to connect different bluetooth enabled units for data transfers between these units. It is a simple method used for sending files wirelessly over a short distance.



RELAY

Relays allow very small current switch to operate a very large current circuit. It isolate one circuit from another ie one circuit is controlled by another but something not compactable. It is magnetic controlled on small current side which pulls the contacts closed on large current draw circuit. It takes relatively small amount of power to turn on a relay but a relay can control something that draws more power. It is used as a shocker in our project.



3.4 BUZZER

An electro mechanical buzzer it is one of the cheapest way to generate a sound from a DC source. Piezoelectric buzzer is a flat piece of piezoelectric material with two electrodes. This type of buzzer requires some kind of external source such as a DC voltage to drive it. They are cheap and sound will be very loud without using very much power.



3.5 GPS AND GSM MODULE

GPS stands for Global Positioning System by which anyone can always obtain the position information anywhere in the world and Location of women along with an emergency Short Message Service (SMS) is sent to police and relatives by GSM module. Global System for Mobile (GSM) is an architecture used for mobile communication in most of the countries.

Figure 1: GPS



Figure 2: GSM

3.6 SENSORS

The women safety device senses the emergency situation with the help of sensors which are the following

- Temperature sensor - this sensor sense woman’s body temperature and sends the generated analog data to controller.
- Pulse sensor - this sensor sense the women’s pulse and generate an analog data to admin.
- Force sensor – this sensor sense the force which applied to the smartband

TEMPERATURE SENSOR



FORCE SENSOR



PULSE SENSOR



4. STEPS

STEP 1:- connect smart band with mobile app using Bluetooth.

STEP 2:- In emergency situation women can double tap on the screen. It activates the shocker circuit on the surface of the screen through relay.

STEP 3:- Buzzer is used as alarm to generate beep sound in the above conditions. It helps to create attention of people who are near to that place for helping.

STEP 4:-The Bluetooth used to send messages to mobile when in danger situation.

STEP 5:-Mobile will send message to ICE numbers with location using android app and GPS.

STEP 6:-GPS is used to track the location and hence GPS of the phone needs to be kept ON.

According to the body temperature and pulse rate it tells the women is in danger or not. It confirmed by asking whether she is in danger by sending message or voice to the user by the admin. If she is in danger encoded message sent to the ICE contacts.^[9] If she is not the just send the health condition to her phone. If she double tap the button again admin send message to her phone and ask whether she is in danger. If she answered yes send messages to ICE contacts. If she didn't answer after 5 min then also message is passed to ICE. Message contains the location and if needed we can include voice, video etc. If the attacker tries to remove the band then he got shock from the band it will get a chances of escaping. There is a buzzer which produce a beep sound it create a local attention from others.

5. RESULT

This system helps to reduce crime and this work attempts to keep women safe, it's a portable device so it can be easily carried to any places. This device continuously monitors the pulse rate of user wearing it, if the pulse rate is above the threshold then the signal will be send to mobile application through Bluetooth module. The application indeed sends alert message and call to registered contact. Further an alert message will be sent to police station or Helpline. User don't have to press any button to give an alert message, this is an automatic process. This device is inexpensive, so that common women can use it while travelling outside.

6. CONCLUSION AND FUTURE WORK

We can use voice record, video processing information etc. in future to catch the attacker in short period of time. Using cameras in future will generate a message and pass it automatically to the control room. So we can catch the face of the attacker. It performs the real time monitoring of desired area and detect the violence with a good accuracy. Also we can use it as a pressure checker and something for medical purpose in future.

REFERENCES

- [1] <https://ieeexplore.ieee.org/document/8537376>
- [2] <https://www.urbanoutfitters.com/shop/roar-athena-safety-wearable-device>
- [3] <https://www.gadgetsnow.com/slideshows/7-best-women-safety-apps/photolist/51285625.cms>

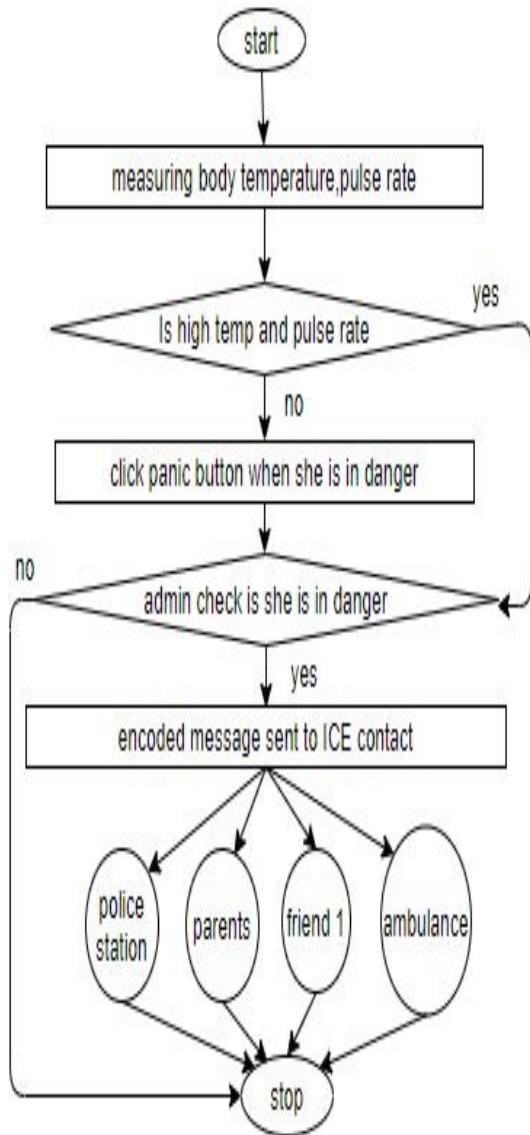

[4] https://www.google.com/search?q=%E2%80%A2+Foot+wear+chip&rlz=1C1SQJL_enAE858AE858&oq=%E2%80%A2%09Foot+wear+chip&aqs=chrome..69i57.534j0j7&sourceid=chrome&ie=UTF-8

[5] https://www.google.com/search?q=%E2%80%A2+VithU%3AV+Gumrah+Initiative&rlz=1C1SQJL_enAE858AE858&oq=%E2%80%A2%09VithU%3AV+Gumrah+Initiative&aqs=chrome..69i57.1363j0j7&sourceid=chrome&ie=UTF-8

[6] https://www.google.com/search?q=Shake2Safety&rlz=1C1SQJL_enAE858AE858&oq=Shake2Safety&aqs=chrome..69i57j0l3.4589j0j7&sourceid=chrome&ie=UTF-8

[7] <https://www.google.com/search?client=firefox-b-d&q=1.%09http%3A%2F%2Fwww.instructables.com%2Fid%2FMake-your-+own-+smart-watch2>.

[8] <https://www.bing.com/search?q=%5B4%5D%09https%3A%2F%2Fwww.pastemagazine.com%2Farticles%2F201+6%2F04%2F5-tech-products+that+are+made+for+women+safety.html&FORM=EDGNCT&PC=LCTS&refig=f986dbcbf811430bb49bbea83ab8f2e5>

[9] <https://www.google.com/search?client=firefox-b-d&q=WOMEN+SAFETY+SMART+BAND>

[10] <https://www.google.com/search?client=firefox-b-d&q=RELAY/AURDINO/BUZZER>