



A Robust power saving Topologically-Compressed With 21 Transistor's Flip-Flop using Multi Mode switches.

¹M.S.Amreen

²B.Ravi Kumar

¹ M.Tech Student Department of ECE (VLSI DESIGN) ,INDIA, amreen.mahammad@gmail.com

² Assistant Professor, Department of ECE,,INDIA, rav.kumar37@gmail.com

ABSTRACT

An extremely low-power flip-flop (FF) named topologically- compressed flip-flop (TCFF) is proposed. As compared with conventional FFs, the FF reduces power dissipation by 75% at 0% data activity. This power reduction ratio is the highest among FFs that have been reported so far. The reduction is achieved by applying topological compression method, merger of logically equivalent transistors to an unconventional latch structure. The very small number of transistors, only three, connected to clock signal reduces the power drastically, and the smaller total transistor count assures the same cell area as conventional FFs. In addition, fully static full-swing operation makes the cell tolerant of supply voltage and input slew variation. An experimental chip design with 40 nm CMOS technology shows that almost all conventional FFs are replaceable with proposed FF while preserving the same system performance and layout area.

Index Terms—Flip-flops, low-power, VLSI.

1. INTRODUCTION

The mobile market keeps on expanding. In addition to the conventional mobile phone, digital camera, and tablet PC, development of various kinds of wearable information equipment or healthcare associated equipment has newly prospered in recent years. In those kinds of battery-working equipment, reduction of power is a very important issue, and demand for power reduction in LSI is increasing. Based on such background, various kinds of circuit

technique have already been proposed. In LSI, generally more than half of the power is dissipated in random logic, of which half of the power is dissipated by flip-flops (FFs). During the past dozen years, several low-power FFs have

been rushed into development. However, in actual chip design, the conventional FF is still used most often as a preferred FF because of its well-balanced power, performance and cell area. The purpose of this paper is to present a solution to achieve all of the goals: power reduction without any degradation of timing performance and cell area. propose FF realization with a new methodology.

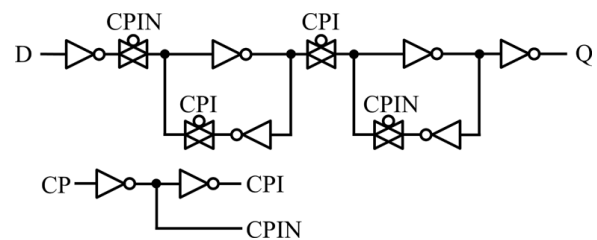

Fig. 1. Conventional transmission-gate flip-flop (TGFF).

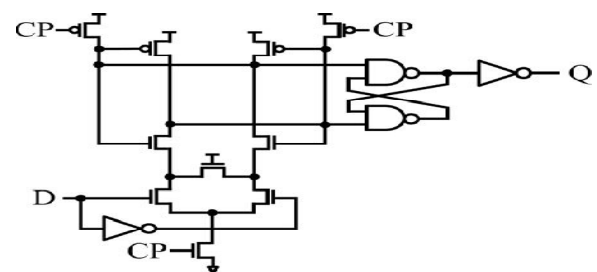

Fig. 2. Differential sense-amplifier flip-flop (DiffFF).

the detailed power and performance characteristics are shown

2. BACKGROUND

Typical low-power FFs with comparison to a conventional FF shown in Fig. 1. Fig. 2 shows a typical circuit of differential sense-amplifier type FF (DiffFF) [1]–[3]. This type of circuit is very effective to amplify small-swing signals, so is generally used in output of memory circuits. In this FF, however, the effect of power reduction goes down in the condition of lower data activity, because these kinds of circuits have pre-charge operation in every clock-low state. Moreover, if we use reduced clock swing, a customized clock generator and an extra bias circuit are necessary. Fig. 3 shows a circuit of conditional-clocking type FF (CCFF) [4]–[6]. This circuit is achieved from a functional point of view. The circuit monitors input data change in every clock cycle and disables the operation of internal clock if input data are not changed. By this operation, power is reduced when input data are not changed. But unfortunately, its cell area becomes almost double that of the conventional circuit shown in Fig. 1. This article has been accepted for inclusion in a future issue of this journal. Content is final as presented, with the exception of pagination.

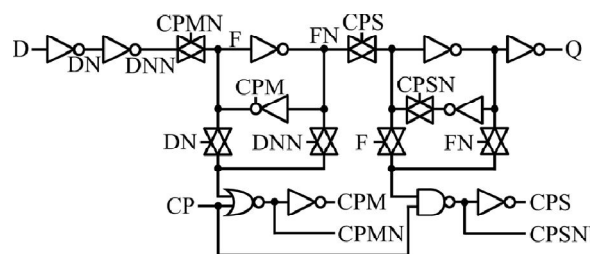

Fig. 3. Conditional-clocking flip-flop (CCFF).

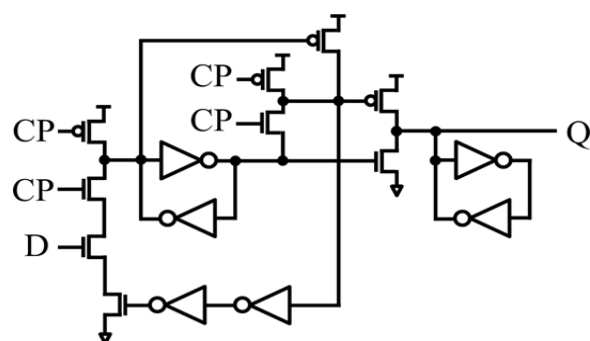

Fig. 4. Cross-charge control flip-flop (XCFF).

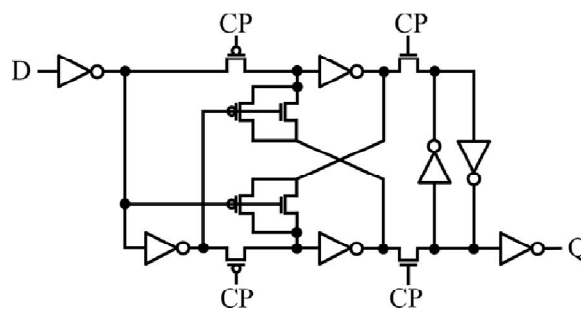

Fig. 5. Adaptive-coupling flip-flop (ACFF).

And mainly due to this size issue, it becomes hard to use if the logic area is relatively large in the chip. Fig. 4 shows the circuit of cross-charge control FF (XCFF) [7]. The feature of this circuit is to drive output transistors separately in order to reduce charged and discharged gate capacitance. However, in actual operation, some of the internal nodes are pre-set with clock signal in the case of data is high, and this operation dissipates extra power to charge and discharge internal nodes. As a result, the effect of power reduction will decrease. Circuits including pre-set operation have the same problem [8]. The adaptive-coupling type FF (ACFF) [9], shown in Fig. 5, is based on a 6-transistor memory cell. In this circuit, instead of the commonly used double-channel transmission-gate, a single channel transmission-gate with additional dynamic circuit has been used for the data line in order to reduce clock-related transistor count. However, in this circuit, delay is easily affected by input clock slew variation because different types of single channel transmission-gates are used in the same data line and connected to the same clock signal. Moreover, characteristics of single-channel transmission-gate circuits and dynamic circuits are strongly affected by process variation. Thus, their optimization is relatively difficult, and performance degradation across various process corners is a concern. Let us summarize the analysis on previously reported low power FFs. For DiffFF [1] and XCFF [7], pre-charge operation is a concern especially in lower data activity. As regards CCFF [4], its cell area becomes a bottleneck to use. And for ACFF.

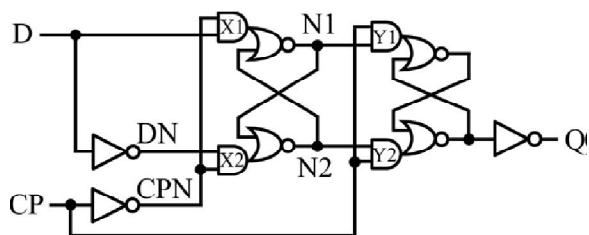

Fig. 6. Example of combinational type FF

[9], tolerance for input clock slew variation becomes subject to resolve.

3. DESIGN APPROACH:

In order to reduce the power of the FF while keeping competitive performance and similar cell area, we tried to reduce the transistor count, especially those operating with clock signals, without introducing any dynamic or pre-charge circuit. The power of the FF is mostly dissipated in the operation of clock-related transistors, and reduction of transistor count is effective to avoid cell area increase and to reduce load capacitance in internal nodes. In the conventional FF shown in Fig. 1, there are 12 clock-related transistors. To reduce clock-related transistor counts directly from this circuit is quite difficult. One reason is because transmission-gates need a 2-phase clock signal, thus the clock driver cannot be eliminated. Another reason is that transmission-gates should be constructed by both PMOS and NMOS to avoid degradation of data transfer characteristics caused by single-channel MOS usage. Therefore, instead of transmission-gate type circuit, we start with a combinational type circuit as shown in Fig. 6. To reduce the transistor-count based on logical equivalence, we consider a method consisting of the following two steps. As the first step, we plan to have a circuit with two or more logically equivalent AND or OR logic parts which have the same input signal combination, especially including clock signal as the input signals. Then, merge those parts in transistor level as the second step.

4. PROPOSED TOPOLOGICALLY-COMPRESSED FLIP-FLOP:

4.1. Proposed FF and Transistor Level Compression

After investigating many kinds of latch circuits, we have set up an unconventionally structured FF, shown in Fig. 7. This FF consists of different types of latches in the master and the slave parts. The slave-latch is a well-known Reset-Set (RS) type, but the master-latch is an asymmetrical single data-input type. The feature of this circuit is that it operates in single phase clock, and it has two sets of logically equivalent input AND logic, X1 and Y1, and X2 and Y2. Fig. 8 shows the transistor-level schematic of Fig. 7. Based on this schematic, logically equivalent transistors are merged as follows. For the PMOS side, two transistor pairs in M1 and S1 blocks in Fig. 8 can be shared as shown in Fig. 9. When either N3 or CP is Low, the shared common node becomes VDD voltage level, and N2 and N5 nodes are controlled by PMOS transistors gated N1 and N4 individually. When both N3 and CP are High, both N2 and N5 nodes are pulled down to VSS by NMOS transistors gated N3 and CP. As well as M1 and S1 blocks, two PMOS transistor pairs in M2 This article has been accepted for inclusion in a future issue of this journal. Content is final as presented, with the exception of pagination.

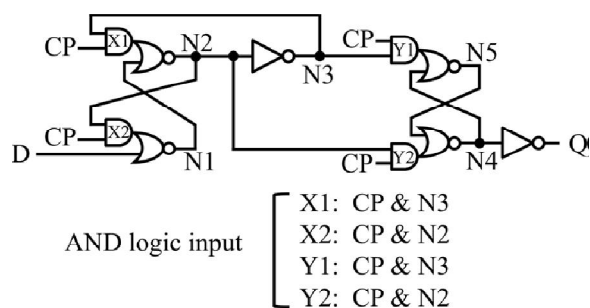

Fig. 7. Schematic diagram of proposed FF.

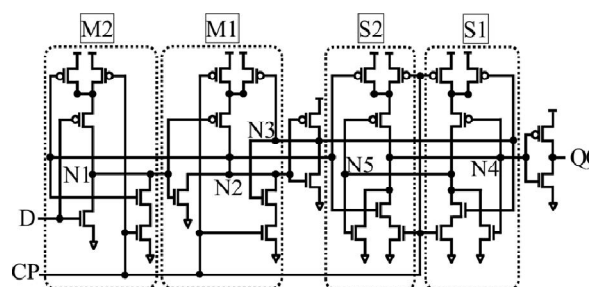

Fig. 8. Transistor level schematic of Fig. 7.

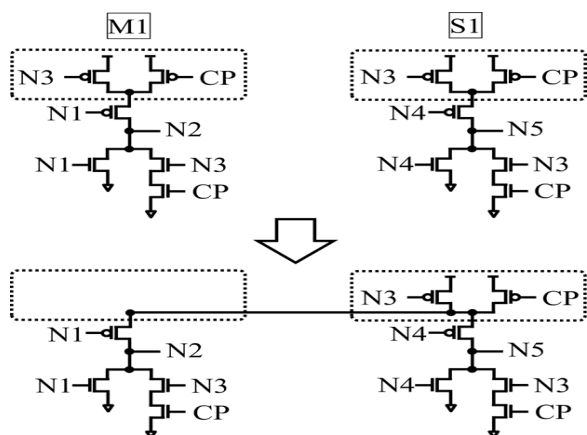

Fig. 9. Transistor merging in PMOS side.

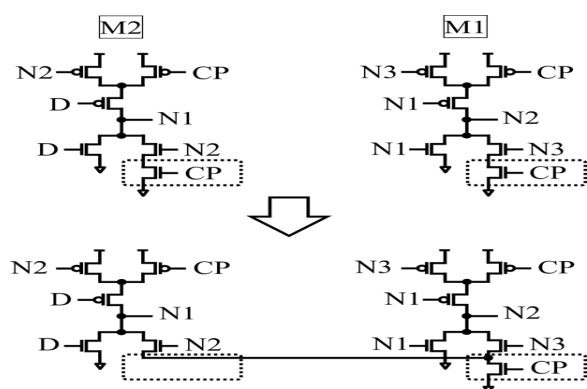

Fig. 10. Transistor merging in NMOS side.

and S2 blocks are shared. For the NMOS side, transistors of logically equivalent operation can be shared as well. Two transistors in M1 and M2 blocks in Fig. 10 can be shared. Transistors in S1 and S2 are shared as well.

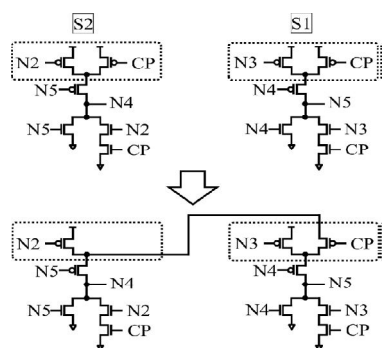

Fig. 11. Further transistor merging in PMOS side.

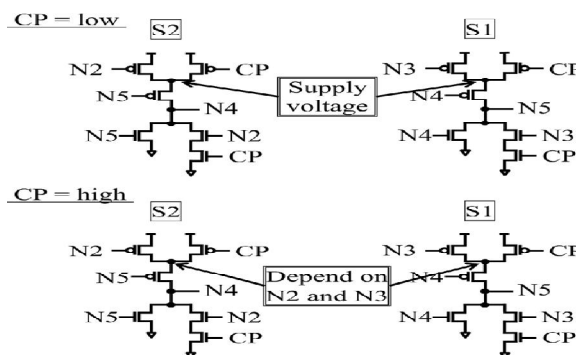

Fig. 12. The state of internal nodes.

Further in the PMOS side, CP-input transistors in S1 and S2, shown in Fig. 11, can be merged, because N2 and N3 are logically inverted to each other. When CP is Low, both nodes are in VDD voltage level, and either N2 or N3 is ON. When CP is High, each node is in independent voltage level as shown in Fig. 12. In consideration of this behavior, the CP-input transistors are shared and connected as shown in Fig. 11. The CP-input transistor is working as a switch to connect S1 and S2. This process leads to the circuit shown in Fig. 13. This circuit consists of seven fewer transistors than the original circuit shown in Fig. 8. The number of clock-related transistors is only three. Note that there is no dynamic circuit or pre-charge circuit, thus, no extra power dissipation emerges. We call this reduction method Topological Compression (TC) method. The FF, TC-Method applied, is called Topologically-Compressed Flip-Flop (TCFF).

4.2 Cell Operation:

Fig. 14 shows simulation waveforms of the circuit shown in Fig. 13. In Fig. 13, when CP is low, the PMOS transistor connected to CP turns on and the master latch becomes the data input mode. Both VD1 and VD2 are pulled up to power-supply level, and the input data from D is stored in the master latch. When CP is high, the PMOS transistor connected to CP turns on. This article has been accepted for inclusion in a future issue of this journal. Content is final as presented, with the exception of pagination.

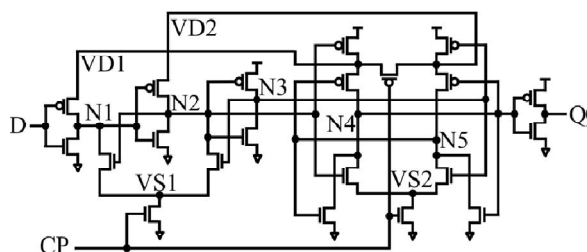

Fig. 13. Transistor level schematic of topologically-compressed flip-flop (TCFF).

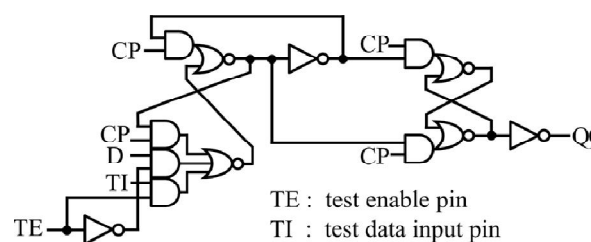

Fig. 14. TCFF with scan type.

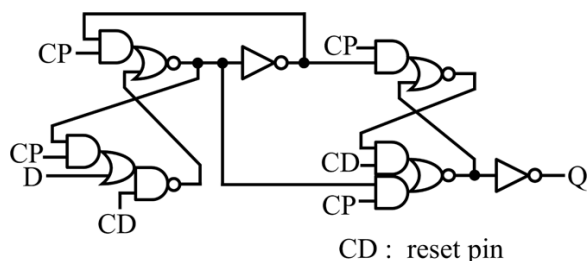

Fig. 15. TCFF with reset type.

off, the NMOS transistor connected to CP turns on, and the slave latch becomes the data output mode. In this condition, the data in the master latch is transferred to the slave latch, and then outputted to Q. In this operation, all nodes are fully static and full-swing. The current from the power supply does not flow into the master and the slave latch simultaneously because the master latch and the slave latch become active alternately. Therefore, timing degradation is small on cell performance even though many transistors are shared with no increase in transistor size.

4.3 Cell Variation:

LSI designs require FFs having additional functions like scan, reset, and set. The performance and cell area for these cells are also important. TCFF easily realizes these cells with less transistor-count than conventional FFs. The circuit diagrams of TCFF with scan, reset, and set are shown in Figs. 15–17. Each circuit can be designed with similar structure, and these FFs also have three transistors connected to CP so the power dissipation is nearly the same as that of TCFF.

4.4 Multi threshold v_{dd} :

Multiple V_t MOS devices are used to reduce power while maintaining speed. High speed circuit paths are designed using low- V_t devices, while the high- V_t devices are applied to gates in other paths in order to reduce subthreshold leakage current. Unlike the multiple- V_{dd} transformation, In addition, multi- V_t optimization does not change the placement of the cells. The footprint and area of low- V_t and high- V_t cells are similar. This enables timing-critical paths to be swapped by low- V_t cells easily. However, some additional fabrication steps are needed to support multiple V_t cells, which eventually lengthens the design time, increases fabrication complexity, and may reduce yield. Furthermore, improper optimization of the design may utilize more low- V_t cells and hence could end up with increased power.

5. RESULTS:

Proposed Flip Flop with 28 transistors :

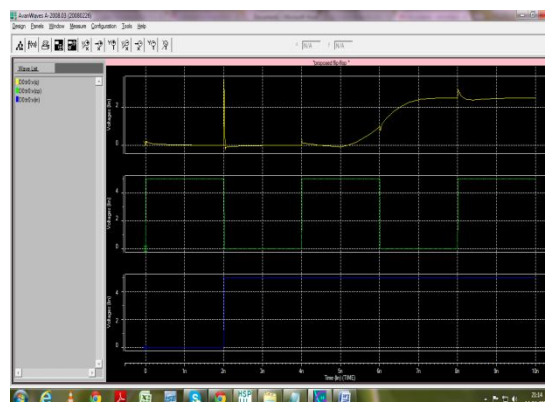

International Journal of Emerging Trends in Engineering Research (IJETER), Vol. 3 No.6, Pages : 358 - 363 (2015)
Special Issue of NCTET 2K15 - Held on June 13, 2015 in SV College of Engineering, Tirupati
<http://warse.org/IJETER/static/pdf/Issue/NCTET2015sp67.pdf>

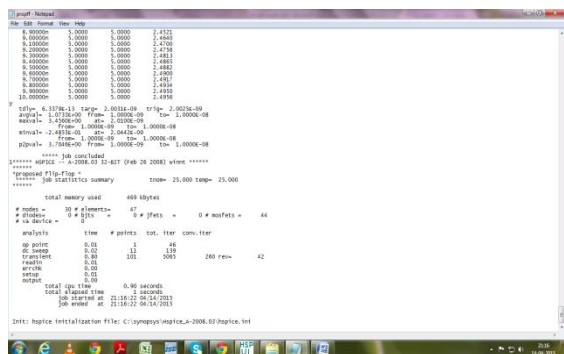

TCFF with 21 transistors:

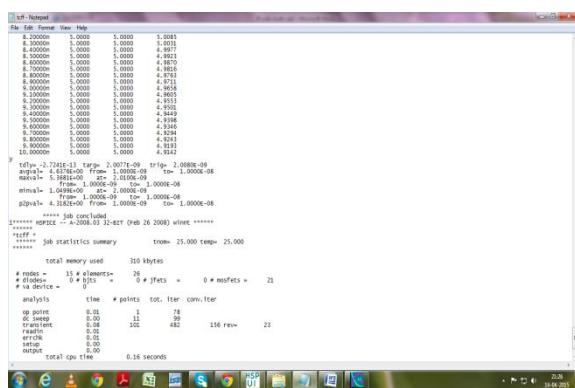
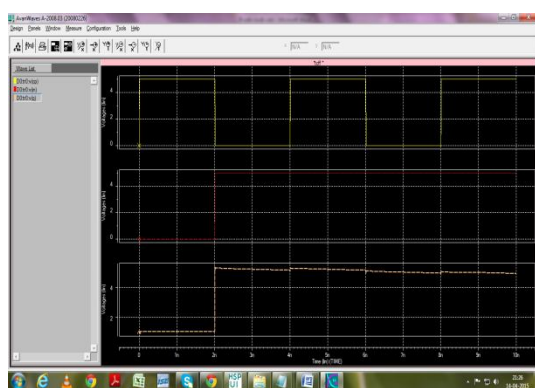

6. CONCLUSION:

An extremely low-power FF, TCFF, is proposed with topological compression design methodology. TCFF has the lowest power dissipation in almost all range of the data activity compared with other low-power FFs. The power dissipation of TCFF is 75% lower than that of TGFF at 0% data activity without area overhead. The topology of TCFF is easily expandable to various kinds of FFs without performance penalty. Applying to a 250 MHz experimental chip design with 40 nm Fig. 27. Power dissipation for TCFF

and the resized TCFF. Fig. 28. Frequency dependence of replacement from TGFF to TCFF and the resized TCFF. CMOS technology, 98% of conventional FFs are replaced by TCFFs. In a whole chip, 17% power reduction is estimated with little overhead of area and timing performance.

REFERENCES

[1] H. Kawaguchi and T. Sakurai, "A reduced clock-swing flip-flop (RCSFF) for 63% power reduction," *IEEE J. Solid-State Circuits*, vol. 33, no. 5, pp. 807–811, May 1998.

[2] J.-C. Kim, S.-H. Lee, and H.-J. Park, "A low-power half-swing clocking scheme for flip-flop with complementary gate and source drive," *IEICE Trans. Electronics*, vol. E82-C, no. 9, pp. 1777–1779, Sep. 1999.

[3] M. Matsui, H. Hara, Y. Uetani, L. Kim, T. Nagamatsu, Y. Watanabe, A. Chiba, K. Matsuda, and T. Sakurai, "A 200 MHz 13 mm²-D DCT macrocell using sense-amplifying pipeline flip-flop scheme," *IEEE J. Solid-State Circuits*, vol. 29, no. 12, pp. 1482–1490, Dec. 1994.

[4] M. Hamada, H. Hara, T. Fujita, C.-K. Teh, T. Shimazawa, N. Kawabe, T. Kitahara, Y. Kikuchi, T. Nishikawa, M. Takahashi, and Y. Oowaki, "A conditional clocking flip-flop for low power H.264/MPEG-4 audio/visual codec LSI," in *Proc. IEEE CICC*, 2005, pp. 527–530.

[5] Y. Ueda, H. Yamauchi, M. Mukuno, S. Furuichi, M. Fujisawa, F. Qiao, and H. Yang, "6.33 mW MPEG audio decoding on a multimedia processor," in *IEEE ISSCC Dig. Tech. Papers*, 2006, pp. 1636–1637.

[6] B.-S. Kong, S.-S. Kim, and Y.-H. Jun, "Conditional-capture flip-flop for statistical power reduction," *IEEE J. Solid-State Circuits*, vol. 36, no. 8, pp. 1263–1271, Aug. 2001.

[7] A. Hirata, K. Nakanishi, M. Nozoe, and A. Miyoshi, "The cross charge-control flip-flop: A low-power and high-speed flip-flop suitable for mobile application SoCs," in *Symp. VLSI Circuits Dig. Tech. Papers*, 2005, pp. 306–307.

[8] K. Absel, L. Manuel, and R. K. Kavitha, "Low-power dual dynamic node pulsed hybrid flip-flop featuring efficient embedded logic," *IEEE Trans. VLSI Syst.*, vol. 21, pp. 1693–1704, Sep. 2013.