

Remotely Monitoring and Controlling Smart Grid Using Zigbee Technology Powered On Renewable Energy Sources

V Prasanth¹, G Tirumala Vasu²

¹PG Scholar, SIETK, Puttur, Andhra Pradesh, India, prasanthnr@gmail.com

² Assistance Professor M.Tech (Ph.D.), SIETK, Puttur, Andhra Pradesh, India, gt7hills81@gmail.com

ABSTRACT

As home energy use is increasing and renewable energy systems are deployed, home energy management system (HEMS) needs to consider both energy consumption and generation simultaneously to minimize the energy cost. This paper proposes a smart HEMS architecture that considers both energy consumption and generation simultaneously. ZigBee-based energy measurement modules are used to monitor the energy consumption of home appliances and lights. A PLC-based renewable energy gateway is used to monitor the energy generation of renewable energies. The remote energy management server aggregates the energy data from numerous home servers, compares them, and creates useful statistical analysis information. By considering both energy consumption and generation, the proposed HEMS architecture is expected to optimize home energy use and result in home energy cost saving¹.

Index Terms : Home Energy Management System, ZigBee, Renewable Energy, Power Line Communication.

1. INTRODUCTION

The current energy crisis has required significant energy reduction in all areas. The energy consumption in home areas has increased as more home appliances are installed. Energy saving and renewable energy sources are considered as methods of solving home energy problem. Both energy consumption and generation should be simultaneously considered to save the home energy cost.

Several researches have proposed home energy management system (HEMS). Optimization of home power consumption based on power line communication (PLC) has been studied to provide easy-to-access to home energy consumption [1], [2]. This work considers a device control module to handle networked home appliances; it does not consider the energy consumption. A green HEMS that monitors, compares, and controls home appliances has been proposed [3], [4]. It does not

consider renewable energies. As solar and wind power system are deployed, energy management systems have been studied to enhance smart home [5], [6]. These works consider only renewable energies, not the energy consumption. In this paper, a smart HEMS architecture that considers both energy consumption and generation based on ZigBee and PLC-based renewable energy gateway (REG), respectively. The home server gathers both the energy consumption data through ZigBee and energy generation data through the REG. By taking into account both consumption and generation, the home server optimizes home energy use.

This paper is extended from a preliminary work [7]. The rest of the paper is organized as follows. Section II describes the proposed HEMS architecture in detail. Section III shows several implementation results for the architecture. Finally, section IV concludes this paper.

2. ARCHITECTURE OF HOME ENERGY MANAGEMENT SYSTEM INCLUDING RENEWABLE ENERGY

A. System Architecture

Although numerous efforts are taken for energy-efficient home appliances [8]-[11], energy management can achieve more energy-efficient home. A new architecture for energy-efficient home is proposed. A home has two parts concerning energy: consumption and generation. Numerous home appliances and lights are in the energy consumption part. Renewable energies such as solar and wind energies are in the energy generation part. Because a home consumes and generates energy, a control device like a home server needs to monitor and control both energy consumption and energy generation to minimize the energy cost. Fig. 1 shows the system architecture of smart HEMS that considers energy-consuming home appliances and lights and energy-generating solar and wind energy resources.

In the energy consumption part, the energy consumption of home appliances and lights is monitored through an energy measurement and communication unit (EMCU) that is installed in each outlet and each light. The EMCU measures the energy and power

consumption of home appliances and lights; it periodically transfers the measured values to the home server. The EMCU communicates with the home server using ZigBee which is well known as a low power communication [12]. The home server gathers the energy and power data from the outlets and lights through a ZigBee access point (AP). It analyzes the gathered data and makes the energy and power usage profile of home appliances and lights. Through the home server, users can browse the energy and power information and figure out the energy usage of home appliances and lights.

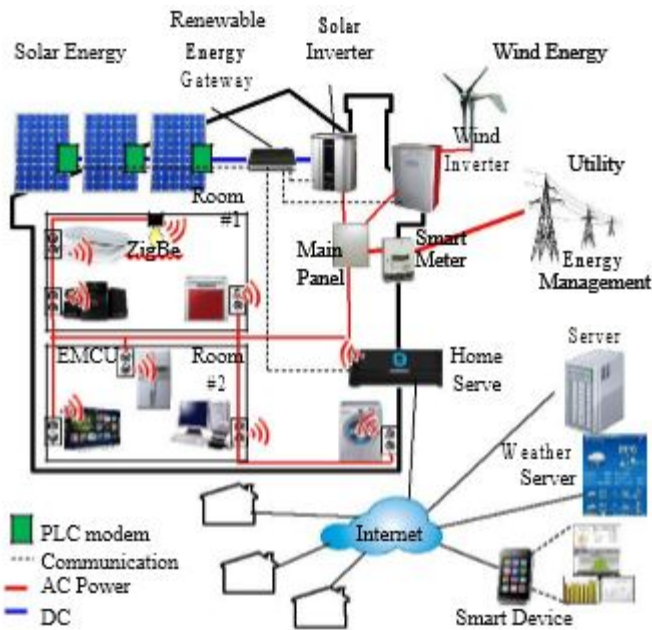

Figure. 1. Architecture of smart home energy management (HEMS) considering both energy consumption and generation.

In the energy generation part, the energy generation of solar and wind power system is monitored through an REG. The solar power system comprises solar panels, PLC modems, a solar inverter, and an REG. A PLC modem is attached on each solar panel; it communicates with the REG. The PLC modems monitor the status of each solar panel and transfer the monitored status data to the REG. The solar inverter converts solar dc power to ac power; it monitors accumulated energy and transient power. The solar inverter is connected to the REG through serial communication. The wind power system comprises a wind turbine and a wind inverter. The wind inverter converts wind power to ac power. It monitors accumulated energy and transient power. The wind inverter is connected to the REG through serial communication. The REG

gathers the status data of the solar panels and two inverters. It transfers the gathered data to the home server through Ethernet. The home server analyzes the gathered data and makes the energy and power generation profile.

As a key component of HEMS, the home server aggregates all the information of energy consumption and energy generation. It has both energy usage profiles and energy generation profiles over time. The home server estimates the amount of renewable energy generation based on weather forecast from Internet. The weather information includes temperature, humidity, cloud amount, and wind speed. Because the home server already stores the past renewable energy generation versus the weather information over time, it has numerous correlations between energy generation and weather. Based on these correlations, the home server estimates the amount of renewable energy generation from the weather forecast. The real-time price of electricity can be acquired from the utility. The home server can manage and control home energy use based on the estimated generation. Users can get various aspects of analysis about the energy information and various recommended control plans to optimize home energy use. They can access the home server through smart phones to browse the home energy information.

If individual homes subscribe a management service, a remote energy management server (REMS) aggregates the energy information from the home servers. The REMS analyzes the aggregated information and creates new information in many aspects. Based on the created new information, the REMS provides an energy portal service and helps client homes compare their energy use with that of others. Users can figure out the average energy information of homes about generation as well as consumption.

B. Home Server

The home server manages the EMCUs installed in outlets and lights through a ZigBee AP. The home server monitors and controls the EMCUs through the node control block. The device table manages both home appliances and lights connected to the EMCUs. The home server identifies home appliances and lights using this table. The energy consumption data of home appliances and lights are stored in the information database. The aggregated data are continuously accumulated over time. The energy consumption manager (ECM) analyzes the aggregated data over time, day, week, and month. It creates energy consumption information such as: energy use patterns of home appliance and lights; total energy use pattern of the whole home. The home server figures out the energy consumption information of a home using this energy consumption manager.

The REG transfers the status data of solar panels, a solar inverter, and a wind inverter to the home server. The transferred data describe the performance of each solar panel, the solar power system, and the wind power system. The data aggregator gathers the transferred data and stores them in the information database. The home server uses weather data and stores them in the information database. The weather data is used to generate the correspondence between energy generation and weather. The energy generation manager (EGM) analyzes the renewable energy generation and draws patterns over weather. Solar energy generation relates to the solar radiation; wind energy generation relates to the wind speed. The EGM can estimate renewable energy generation based on the weather forecast.

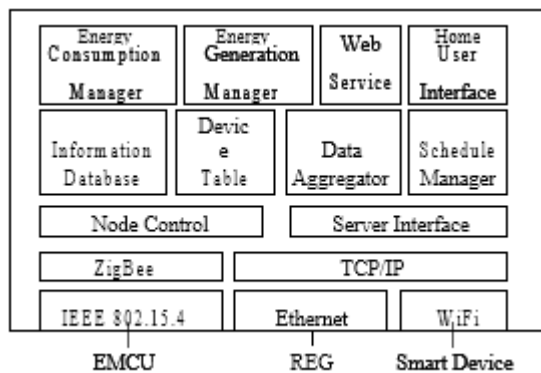

Figure. 2. Function blocks of a home server.

The home user interface (UI) provides a variety of contents about home energy information to home users. The UI shows the energy consumption and generation information over time. Users can browse and check the energy usage of each home appliance and each light; they can also figure out how much energy is being generated and how much cost is being saved.

The web service enables smart devices to access the home server and search the home energy information. Users can browse the home energy information through smart devices anytime and anywhere through Internet. The home server provides the contents to smart devices on demand. The smart devices can directly access the information using smart device applications. The home server transfers the home energy information to the REMS that manages numerous client homes.

C. Energy Management and Communication Unit (EMCU)

In the energy consumption part, the EMCU is a key component; it is composed of measurement and communication blocks [3]. The measurement block measures the power, energy, and

power factor of plugged home appliances. It uses an energy metering IC for measuring them. The metering IC measures the voltage and current in a sample period; it multiplies them; it integrates them continuously. The power and energy is calculated with this process. The power factor is measure based the phase difference between voltage and current. The measurement block stores only the accumulated energy data at a memory; it calculates the power and power factor on demand in real time. The measurement block includes the power control block that supplies or blocks the electricity to connected home appliances.

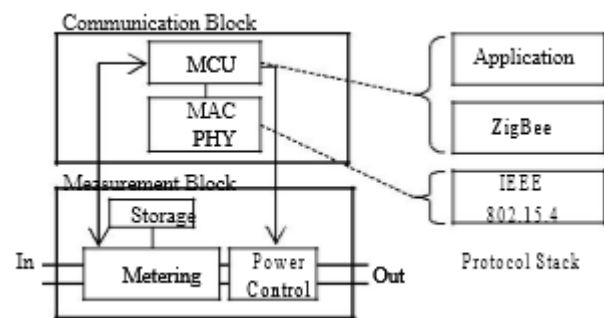

Figure. 3. Energy measurement and communication unit (EMCU) and protocol stack.

The communication block supports data transfer between the EMCU and the home server. It adopts ZigBee and IEEE 802.15.4 wireless personal area network (WPAN) as communication methods. It transfers not only the measured energy, power, and power factor but also the voltage and current. Fig. 3 shows the data transfer message that is loaded on the ZigBee payload. The MCU in the communication block controls the state of the power control block in response to the command from the home server.

Energy (4B)	Power (3B)	Voltage (3B)	Current (3B)	Power Factor (2B)
-------------	------------	--------------	--------------	-------------------

Figure. 4. Data transfer message format in a ZigBee payload.

D. Renewable Energy Gateway and PLC Modem

In the energy generation part, the REG is a key component; it is connected to the PLC modems, the solar inverter, and the wind inverter. The PLC modems communicates with TCP/IP protocol over PLC. They have their own IP address as an identifier. The connection manager controls connection with the REG. The sensing agent measures the voltage and current of a solar panel. The performance can be figured out from those

sensed data. The PLC modem transfers the sensed data to the REG.

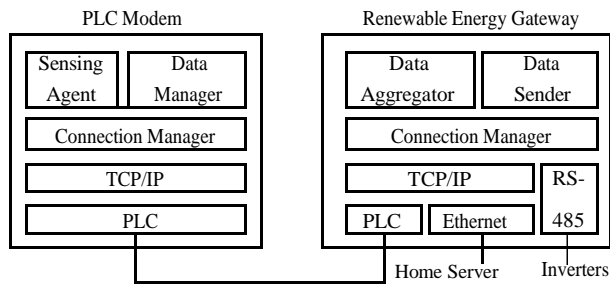

Figure. 5. Architecture of a renewable energy gateway (REG) and a PLC modem.

The REG has three communication interfaces: PLC for each solar panel, Ethernet for the home server, and an RS -485 for inverters [13]. For typical network communication, TCP/IP protocol is used over PLC and Ethernet. The connection manager controls the connection with each PLC modem to aggregate the status data. Solar and wind inverters are connected through the RS-485 interface. The data aggregator sends a data request message to each PLC modem and inverters; it receives the status data. The data sender transfers the aggregated data to the home server periodically.

E. Remote Energy Management Server (REMS)

Individual homes can subscribe the energy portal service that is provided by the REMS. The home server in each home transfers the home energy information to the REMS. The client manager maintains the connection to the home server of subscribers. The REMS aggregates the detailed energy information from the client home server that provides the energy use of home appliances and lights. The energy generation information is also transferred.

All aggregated information is stored in the information database. The REMS calculates the average, maximum, minimum energy usage regarding homes and home appliances. The calculated information shows the standard energy usage pattern. It motivates subscribers to compare their energy usage with that of others and to reduce home energy use. The energy portal service provides numerous subscribers with the statistical energy consumption and generation.

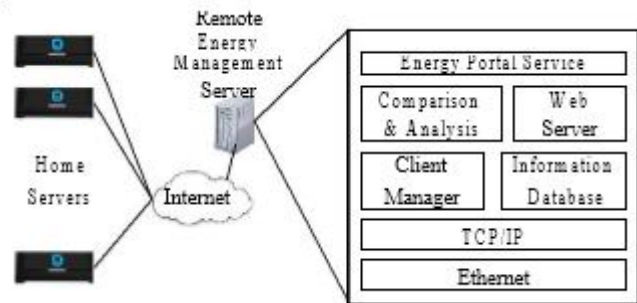

Figure. 6. Remote energy management server (REMS) connected to the home servers of subscribing clients.

3. IMPLEMENTATION RESULTS

The implemented results show several developed components: home server, REMS, EMCU, PLC modem, and REG. Those developed components are installed in the laboratory and operated.

Fig. 7(a) shows the miniaturized test set that includes a smart device, EMCU-installed outlets, a light and a solar power system. Fig. 7(b) describes the energy usages of home appliances and lights. Various usage patterns can be obtained. Total energy use and cost are also shown. Users can select a specific home appliance on the menu. Fig. 7(c) shows the node mapping information. Home appliance and lights are mapped to a certain region in a home. Fig. 7(d) describes the device lists and its properties. User can check the characteristics of home appliances and lights. Fig. 7(e) shows the solar power system information.

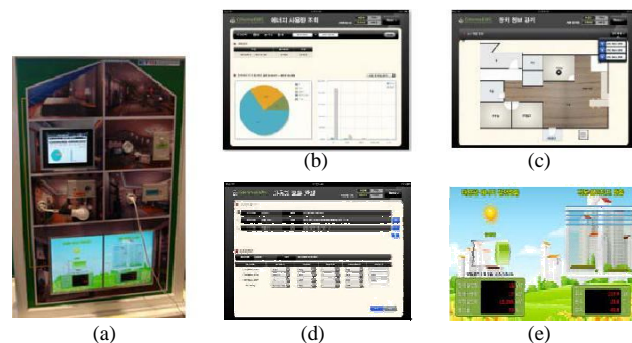

Figure. 7. Home server user interfaces. (a) Test set, (b) Energy usages of home appliances and lights, (c) Mapping information, (d) Device lists, (e) Solar power system information.

Fig. 8 shows the user interfaces of the REMS. Fig. 8(a) describes the electricity use data UI. The top graph shows the electricity use on months; the pie chart on the bottom left the electricity use ratio; the graph on the bottom right the electricity use over hourly time. Fig. 8(b) shows the statistical information about numerous homes.

The bottom graph describes the energy use over time for comparison of each home.

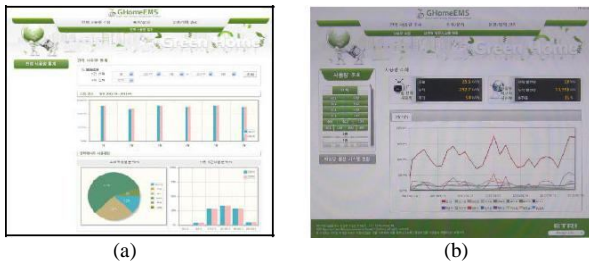

Figure 8. User interfaces of the remote energy management server (REMS).

Fig. 9 shows the back side of the miniaturized test set. The prototype EMCU is inserted between an AC power line and an outlet. It measures and controls the electric power of the outlets. Three EMCUs are installed: one for a light, two for home appliances. These EMCUs transfer the measured data to the home server using ZigBee communication.

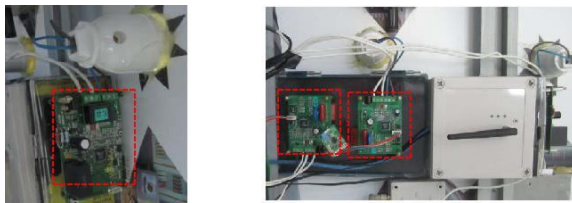

Figure 9. Energy management and communication unit (EMCU) installed in the miniaturized test set.

Fig. 10 shows the developed hardware boards: a PLC modem and a renewable energy gateway (REG). The PLC modem is composed of two parts: a sensing and a PLC communication as shown in Fig. 10(a). The sensing part uses a hall-effect current sensor and a voltage divider to measure the current and voltage, respectively. The PLC communication part uses a standard PLC technology interoperable with IEEE 1901 standard. The boxed region is a PLC PHY/MAC area. Fig. 10(b) shows the REG that communicates with two inverters through RS-485 interfaces and numerous PLC modems through a PLC interface.

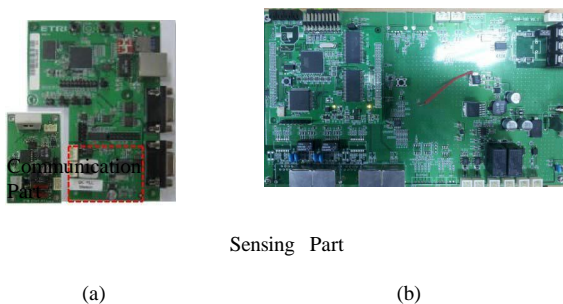

Figure 10. Components for renewable energy monitoring. (a) PLC modem, (b) Renewable energy gateway (REG).

4. CONCLUSION

As residential homes have installed renewable energy sources to save the energy cost, it is important that both energy consumption and generation are simultaneously considered in HEMS. This paper proposes the smart HEMS architecture that considers both consumption and generation. In the energy consumption, the EMCUs are installed in outlets and lights to measure the energy usages of home appliances and lights based on ZigBee; they transfer the gathered data to the home sever. With this scheme, the home server figures out the home energy usage pattern. In the energy generation, PLC modems are installed in each solar panel to monitor its status. The REG gathers the status data of the solar panels based on PLC and the generation data from inverters based on RS-485; it transfers the gathered data to the home server.

This PLC monitoring technology can monitor each solar panel for maintenance. The home server can estimate the energy generation based on a weather forecast. Using the obtained energy information, the home server can control the home energy use schedule to minimize the energy cost. Users can access the home energy information through smart devices. The REMS provides the comparison and analysis of each home energy usage. By considering both consumption and generation, the proposed architecture is expected to enhance home energy management and to save the energy cost.

ACKNOWLEDGEMENT

I would express my deep sense of gratitude to thank my mentor & guide Mr.G.Tirumala Vasu., M.Tech.,(Ph.D.),Assistance Professor department of ECE, SIETK, Puttur, Andhra Pradesh for his constant support & guidance. His active cooperation and involvement have helped me through the various stages of project development.

I would also express my gratitude to Dr.M.Janardhana Raju M.E.,Ph.D.,H.O.D.Dept of ECE.for his thoughtful recommendations and suggestions.

REFERENCES

1. Young-Sung Son and Kyeong-Deok Moon, "Home energy management system based on power line communication," in *Proc. IEEE International Conference on Consumer Electronics*, Las Vegas, USA, pp. 115-116, Jan. 2010.

2. Jinsoo Han, Chang-Sic Choi, Wan-Ki Park, and Ilwoo Lee, **“Green home energy management system through comparison of energy usage between the same kinds of home appliances,”** in *Proc. IEEE International Symposium on Consumer Electronics*, Singapore, pp. 1-4, Jun. 2011.
3. Chia-Hung Lien, Hsien-Chung Chen, Ying-Wen Bai, and Ming-Bo Lin, **“Power monitoring and control for electric home appliances based on power line communication,”** in *Proc. IEEE International Instrumentation and Measurement Technology Conference*, British Columbia, Canada, pp. 2179-2184, May 2008.
4. Saeed Jahdi and Loi Lei Lai, **“Grid integration of wind-solar hybrid renewable using AC/DC converters as DG power sources,”** in *Proc. World Congress Sustainable Technologies*, London, UK, pp. 171-177, Nov. 2011.
5. Hayato Yamauchi, Kosuke Uchida, and Tomonobu Senjyu, **“Advanced Smart Home,”** in *Proc. IEEE International Conference on Harmonics and Quality of Power*, Hong Kong, China, pp. 130-135, Jun. 2012.
6. Jinsoo Han, Chang-Sic Choi, Wan-Ki Park, Ilwoo Lee, and Sang-Ha Kim, **“Smart home energy management system including renewable energy based on ZigBee and PLC,”** in *Proc. IEEE International Conference on Consumer Electronics*, Las Vegas, USA, pp. 544-545, Jan. 2014.
7. Namsik Ryu, Jae-Ho Jung, and Youngchae Jeong, **“High-efficiency CMOS power amplifier using uneven bias for wireless LAN application,”** *ETRI Journal*, vol. 34, no. 6, pp. 885-891, Dec. 2012.
8. C. Arm, S. Gyger, J. Masgonty, M. Morgan, J. Nagel, C. Piguet, F. Rampogna, P. Volet, **“Low-power 32-bit dual_MAC 120 uW/MHz 1.0V icyflex1 DSP/MCU core,”** *IEEE Journal of Solid-State Circuits*, vol. 44, no. 7, pp. 2055-2064, Jul. 2009.
9. Hyoungsik Nam and Hoon Jeong, **“Data supply voltage reduction scheme for low-power AMOLED displays,”** *ETRI Journal*, vol. 34, no. 5, pp. 727-733, Oct. 2012.
10. Hyunho Park and Hyeong Ho Lee, **“Smart WLAN discovery for power saving of dual-mode terminals,”** *ETRI Journal*, vol.35, no.6, pp.1144-1147, Dec. 2013.
11. Hyung Seok and Jiwon Yoon, **“Hybrid distribution stochastic addressing scheme for ZigBee/IEEE 802.15.4 wireless sensor networks,”** *ETRI Journal*, vol. 33, no. 5, pp. 704-711, Oct. 2011.
12. Jinsoo Han, Chang-Sic Choi, Wan-Ki Park, Ilwoo Lee, and Sang-Ha Kim, **“PLC-Based Photovoltaic System Management for Smart Home Energy Management System,”** in *Proc. IEEE International Conference on Consumer Electronics*, Las Vegas, USA, pp. 542-543, Jan. 2014.