

Analysis of a Neural Network Based Distributive Power Flow Controller (DPFC) for Power System Stability

V.Anwasha Kumar¹, G.MadhusudhanaRao², B.V.sankar Ram³

¹Research Scholar, JJIIT, JNTUH, nanivip@gmail.com

²Professor, TKR College of Engineering and Technology, Hyderabad, AP, India

³Professor of EEE, JNTUH Hyderabad, AP, India



Abstract: The Unified power Flow Controller (UPFC) is effective equipment in controlling the power flow in the new deregulated electricity markets. The UPFC realizes its function by changing part or all of the parameters affecting flowing of the power in a transmission line. These parameters include the bus voltages, the line impedance and the power angle. The UPFC is by far the most advanced and versatile device in the Flexible AC Transmission System (FACTS) device family. However, several problems, reliability, cost, and footprint requirement, hinder its widespread acceptance by the electric utilities. To overcome the drawbacks of the conventional UPFC, this work proposed and studied a new UPFC technology that addresses these impediments. This novel technology is called the Distributed PFC (DPFC). The proposed DPFC is based on single-phase system, considering the high voltage insulation, the manufacturing cost, and the installation requirement. A hierarchy control of the DPFC system is proposed, which includes local unit control and a central control unit. The central control unit calculates series voltage and shunt real/reactive power commands for every DPFC unit. The local DPFC unit accepts commands from the central control unit, monitors local voltage at the connection point, and realizes its control commands. The functions and performance of the DPFC system is verified with simulation and experiments.

Keywords: Flexible AC Transmission System (FACTS), Unified Power Flow Controller, Power Regulation, Power Converter, Real Time Control

I. Introduction

The basics of power flow control can be understood by considering a purely inductive transmission line connecting two buses, as suggested in Figure 1-1(a).

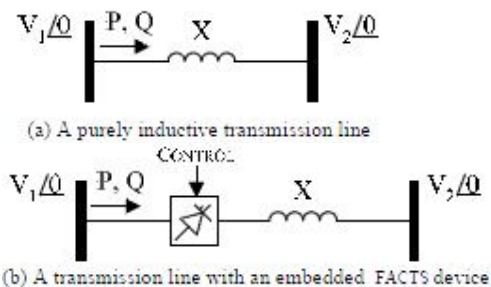

Figure 1-1: Schematic illustration of power flow control through transmission line.

Using elementary phasor ideas it can be shown that the complex power flow measured at the bus 1 of the line is given by,

$$S = P + jQ = -\frac{V_1 V_2}{X} \sin \theta + j \left(\frac{V_1^2}{X} - \frac{V_1 V_2}{X} \cos \theta \right) \quad \dots \text{Eqn 1-1}$$

where P and Q are the active and reactive power, respectively. It can be seen from Equation (1-1) that value of the power flow depends upon four parameters, namely, the magnitude of the voltage at each bus, V1 and V2, the transmission angle and the line reactance, X. Consider now the insertion of a FACTS device as shown in Figure 1-1(b). By means of a power electronics based control, FACTS devices are able to modify one (or more) of the parameters that define the power flow equation, and therefore realize power flow

control. This simple but powerful idea is the core of FACTS technology. It is evident from Equation (1-1) that the modification of any of the parameters affects both the active and reactive power simultaneously. Table 1-1 shows the sensitivity functions of the complex power with respect to the system parameters for a typical set of values encountered in a power system.

Table 1-1 : Complex power sensitivities.

$V_1 = V_2 = 1 \text{ pu}$, $\theta = 10^\circ$, $X = 0.5 \text{ pu}$.

$\frac{\partial}{\partial \downarrow}$	P	Q
θ	1.97	0.35
X	-0.69	-0.06
V_1	0.35	2.03

As can be seen, the transmission angle and the line reactance have a much bigger relative influence on the active power while the value of the bus voltage mostly affects the value of the reactive power. Thus, the control of either the transmission angle or the line reactance can be considered as active power compensation whereas the control of the bus voltage can be considered as reactive power compensation. This decoupling effect has been successfully used in other areas of power engineering as well, such as the DC power flow method [4, 5].

FACTS devices have several purposes:

1. To increase the capacity of the existing power transmission system.
2. To control the power flow in desired transmission route.

3. To provide dynamic stabilization enhancement for the transmission system.
4. To provide system optimization control, when a large number of FACTS devices are installed on the power system.

Inspired by the way the traditional electro-mechanical system control the power transmission, researchers and engineers came up with the power-electronics based FACTS controllers. Compared with the traditional electro-mechanical system control. FACTS devices have the following advantages [13]:

1. The main advantage of FACTS over simple mechanical devices is their near-instantaneous response to changes in the system voltage.
2. Lower maintenance requirements without rotary parts.
3. Lower losses compared with mechanical/rotary compensators.
4. High reliability.
5. Possibility of individual phase control.

II. Literature Survey

Although the concept of FACTS was introduced by Dr. Narain G. Hingorani as a response of modern power systems needs, the aim of controlling power flows in transmission network is not new. Ever since power systems were conceived, there was an interest in controlling the power flows through the transmission network. The development of high-power semiconductors with turn-off capability paved the way to the next generation of FACTS devices. Led by Dr. Laszlo Gyugyi, a group of engineers from SIEMENS have developed the Static Synchronous Compensator (STATCOM) [15], the Static Synchronous Series Compensator (SSSC) [16], the Unified Power Flow Controller (UPFC) [17], and the Interline Power flow Controller (IPFC) [18]. Together, these devices constitute the family of voltage source DC link power flow controllers that have been unified under the Convertible Static Compensator (CSC) [19]. Figure 2-1 shows the various ways these devices are embedded into a transmission line.

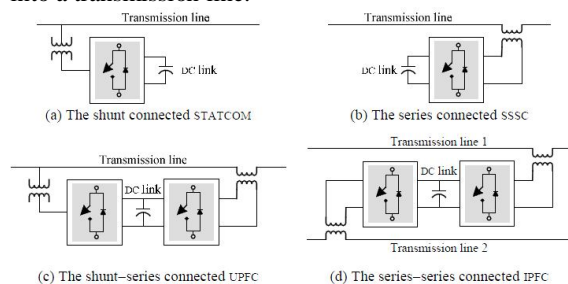

Figure 2-1: Schematic diagrams of DC link realizations for power flow control.

The STATCOM and the SSSC have, respectively, an analogous function to the SVC and TCSC i. e., the STATCOM provides voltage support and the SSSC injects quadrature voltage into the line hence realizing active power flow control. The UPFC can simultaneously and selectively provide voltage support,

and realize active and reactive power through the line. Lastly, the IPFC can provide series compensation to two (or more) transmission lines and also allow transfer of real power between the cross-connected lines.

It is important to notice that for each of these devices the inverter realization as well as the modulation strategy can take different forms [20]. Finally, a few devices that follow the approach of fast switching direct AC \leftrightarrow AC conversion without frequency change to realize power flow control have recently appeared in the literature.

The research has been conducted in terms of matrix converter [21] based power flow controllers [22, 23] and in terms of more restricted configurations such as the vector switching converter (VeSC) [24-28]. This research focuses on the next leap introducing fast switching FACTS devices with the potential of better performance and controllability.

III. Unified Power Flow Controller (UPFC)

The UPFC concept was proposed by Gyugyi in 1991. As its name implied, UPFC can change all the parameters affecting power flow in the transmission line, including the voltage magnitude, the line impedance, and the power angle. Figure 3.1 illustrates the typical structure of a UPFC. It has two switching converters, the shunt converter and the series converter, sharing the same DC link capacitor. The unique characteristic of the UPFC is that the real power can flow between those two converters. Converter2 can inject a voltage into the transmission line V_c with controllable magnitude and phase angle. Reactive power exchanged between converter2 and converter1 is generated locally in itself. Converter1 can supply or absorb the real power demanded by converter2. At the same time, converter1 also works as a STATCOM controlling the bus voltage. In the UPFC, the converter2 provides the main function by injecting a voltage V_c into the transmission line. The magnitude of the injected voltage can be in the range of 0 to the maximum voltage rating of the converter2. Its phase angle can be from 00 to 3600. [28-30].

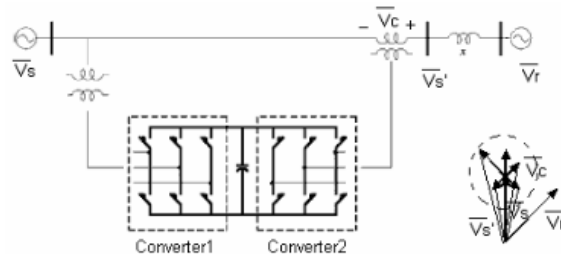

Figure 3-1: Typical Configuration of UPFC.

The development of the converter-based FACTS devices is progressing rapidly. There are numerous researchers in universities and industry working in this area. The most recent FACTS devices include Interline Power Flow Controller

(IPFC) [21], Unified Power Quality Conditioner (UPQC) [22], to just list a few of them. Research is also being conducted on FACTS devices with energy storage components, like battery storage and Super Conducting Magnetic Energy Storage (SMES) [23-26]. The FACTS device is a proven technology in power transmission application. There have been quite a few installations. Those installations include WAPA's Kayenta advanced series capacitor (in fact, a TCSC), BPA's Slatt Thyristor Controlled Series Capacitor (TCSC), North-South interconnection TCSC, Stode TCSC in Sweden, TVA's Sullivan Static Condenser (STATCOM), AEP's Inez unified Power Flow Controller (UPFC), etc. [13, 27] This work mainly focuses on the UPFC application in addressing the problem of power flow control and voltage regulation.

In this paper, the capability of UPFC on controlling of the power flow and the effectiveness of controllers on performance of UPFC in the power transmission line are examined by using different control mechanisms based on PI and neuro controllers. In the modeling of fuzzy controller, Takagi-Sugeno Inference System is used in the decision making process and "Weighted Average" method which is the special case of "Mamdani" model is used in the defuzzification process. The Matlab-Simulink software is used to create UPFC model and to obtain the results of case studies.

IV. Proposed DPFC System Structure

The above discussed Unified Power Flow Controller (UPFC) offers good promise to enhance the performance of the electric power grid by providing voltage stability while improving the power flow potential. The UPFC of present technology is typically located at either the sending end or receiving end of a transmission line. It will be referred to as a concentrated UPFC (CUPFC). There are three major problem areas associated with the CUPFC that have hindered its widespread acceptance by the electric utilities - reliability, cost, and footprint requirement. This work studies a new UPFC technology that addresses these three impediments. This novel technology is called the Distributed Power Flow Controller (DPFC). The following discussion clarifies the problems attributed to the CUPFC while introducing the DPFC advantages. The CUPFC is a custom design assembled on site making the initial cost prohibitively expensive except for locations in the grid where performance is extremely deficient. The CUPFC has a price tag in the \$250/kVA. The proposed DPFC lends itself to a standard design suitable for assembly line manufacture. The implementation of the emerging SiC or CVD switch technology should allow use of simple SPWM switching schemes rather than the transformer mixing of 24-48 step waveforms as done with the present CUPFC technology. Further, the

high voltage capability of the emerging switches has the potential to operate the shunt portion of the DPFC with direct connection to the transmission level voltages. The magnetics of the CUPFC are half, or more, of the total device volume and form a significant portion of the initial cost. Between the assembly line manufacturing process and the reduction in the required magnetics, it is anticipated that the DPFC initial cost can be in the \$100/kVA range. The DPFC should also show advantage in maintenance cost. Warehousing of spare units will now be practical. Replacement of failed units can be handled by utility linemen. Failed units can be serviced at repair centers.

To the problems the CUPFC confronts, this work provides a feasible solution – the Distributed PFC (DPFC). Same as the personal computer to main frame, the concept of the DPFC intends to utilize the economics of scale to decrease the cost, complexity, and to improve the reliability of the UPFC system. The Proposed structure of a DPFC Simulink model unit is shown in Figure . A certain number of DPFC units are installed along the transmission line between two buses. The number of DPFC units is decided by the total required kVA rating divided by the kVA rating of single DPFC unit.

For implementation, a central control unit accepts control commands from the system operator. Those commands include real and reactive power to be transmitted from one bus to the other, and the voltage to be controlled at some point along the transmission line. The central control unit computes the total required series voltage, and the shunt real and reactive power based on control commands, sampled voltage and power flow data from the transmission line. It also calculates series voltage and shunt real/reactive power commands, V_{se_n} and Q_{sh_n} , for every DPFC unit. The central control unit provides an efficient interface between the system operator and the power transmission system. It also monitors working conditions from the field. The communication between the central control unit and the power transmission line and the DPFC units can be done by power line carrier signal or by wireless signal through communication satellite.

A. Neural network predictive control: Design and Algorithm

The proposed neural network predictive controller employs a neural network for identifying the non linear test system under consideration. The neural identifier that identifies the test system (including the UPFC) under consideration uses the current value and the value at three previous instants of the quadrature component of the series injected voltage V_q and the active output power P at four previous instants as

inputs to predict the current value of the active output power. Hence, it is a two-layer feed forward neural network with 8 inputs, a single hidden layer with 15 sigmoidal neurons and one linear output neuron. The data required for training the network is generated from simulation of the operation of the test system under consideration by applying randomly generated values technique. As the rotor angle oscillations are to be damped by controlling the active power P effectively to the steady state level, the controller minimizes the difference between the actual value of the active power and its steady state value over some specified future time horizon. It also minimizes the deviation in the control action making it smooth and ensuring its steady state behavior. The actual value of the active power at future time instants corresponding to the tentative control inputs are predicted by the neural identifier. The cost function used in this work employs the Integral Square Error (ISE) criterion. It consists of squared deviations between the reference and predicted active power values and the weighted square of the change in control input over successive future time instants. Structure of Neural Network is shown in Figure : 4-1.

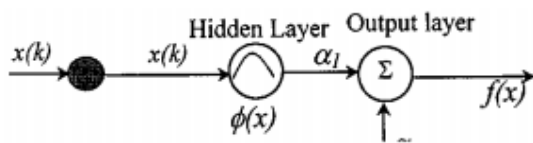

Figure 4-1 : Structure of Neural Network.

for Vq to the plant at regular intervals of 0.03125 second. The Backpropagation algorithm employing the Levenberg-Marquardt algorithm for faster convergence is used to train the neural network shown in Fig. 4 to identify the plant. The proposed neural network predictive controller is based on the receding horizon

Neural network based control systems have been suggested for many control applications using either feed-forward or recurrent neural networks. Most of them are built around a feed-forward neural network included inside a traditional control system.

In this paper a model Voltage reference NN Controller network as shown in Figure 4-2 is used for the generation of control signals. It consists of two neural networks, one identified as plant network and the other as controller network. The two networks are trained such that the plant network is identified first and then the controller network is trained in a way that the plant output follows the reference model output.

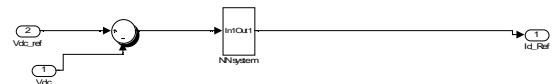

Figure 4-2: Voltage reference NN Controller.

The proposed structure of a DPFC Simulink model unit is shown in Figure 4-3.

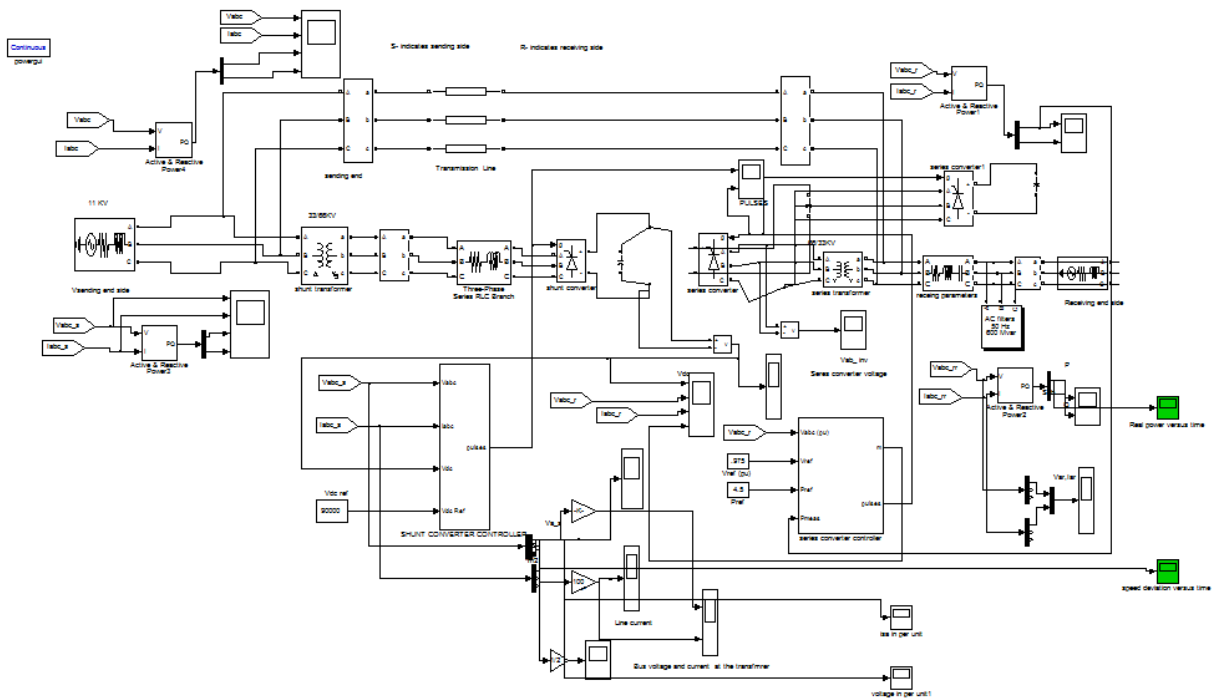

Figure 4-3: Proposed structure of a DPFC Simulink model unit

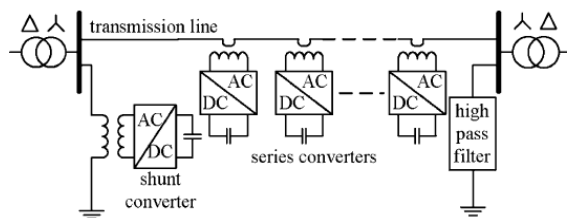

Figure: 4-4 DPFC unit diagram

The local DPFC unit diagram, as demonstrated in Figure 4-4, accepts commands from the central control unit. These commands include series voltage (magnitude and phase angle), and the shunt reactive power, which is to maintain voltage magnitude at certain point along the transmission line. The local unit monitors local voltage at the connection point, which provides phase angle reference for the injected series voltage, and the magnitude and phase angle reference for the shunt voltage. The local DPFC unit works in the same way as the CUPFC works.

The major differences between local DPFC unit and the CUPFC are:

- (1) Rating of the DPFC is smaller than CUPFC. While the CUPFC always rates up to MVAR, the DPFC unit in the DPFC system will be rated at hundreds of kVAR. The small rating of the DPFC unit gives itself the flexibility to be installed on existing transmission tower, to be mass manufactured in assembly lines, and to be maintained individually.
- (2) The control command of DPFC is from the system central control unit, which is to coordinate with other units to maintain certain power transmission state or realize certain control tasks.
- (3) Considering the unit manufacturing cost, especially the insulation cost. The proposed system should be realized on a single-phase basis. A possible unit structure is depicted in Figure 4-5.

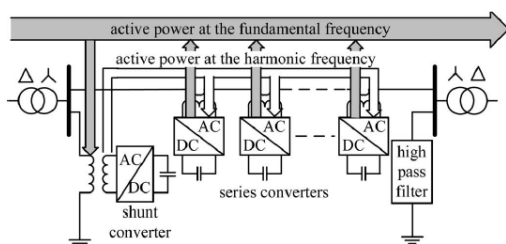

Figure 4-5: A possible unit structure.

V. Simulation Results and Discussions

In this section, the DPFC model is created and simulated on Matlab/Simulink. All the simulations are based on single-phase per-unit system. One shunt

converter and two single phase series converters are built and tested. The specifications of the DPFC in MATLAB are listed below.

PARAMETER	VALUE
Sending end voltage(V_s)	200 V
Receiving end Voltage(V_r)	200 V
Series converter voltage	120 V
Shunt converter voltage	120 V
Line Resistance (r)	0.3864 Ω /km
Line inductance(L)	4.1264 mH/km
Source resistance (r_s)	0.8929 Ω
Source inductance(L_s)	16.58 mH
Series capacitor(C_{se})	1 μ F
Shunt capacitor (C_{sh})	1 μ F

The system under consideration is simulated under different operating conditions to investigate its transient stability performance and to demonstrate the effectiveness of the proposed controller. The contingency under consideration is a three phase fault at the sending end of one of the transmission lines when the generator is operating at different power levels. The fault is considered to occur between $t=0.2s$ and $t=0.3s$. The fault is cleared with the operation of transmission line reclosure.

The following case studies were undertaken to make the assessments and shown in Figure 5-1 to Figure 5-3.

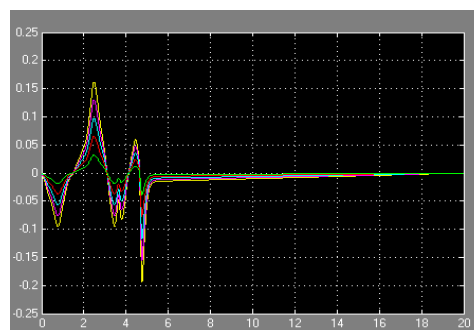

Figure 5-1: Speed deviation versus time

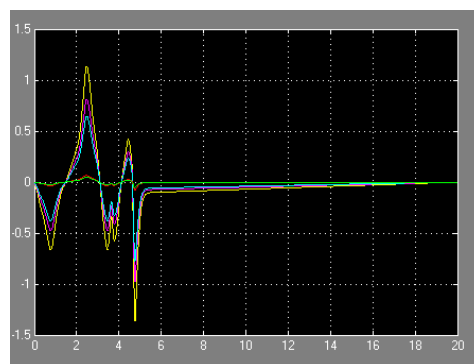

Figure 5-2: Power angle versus time

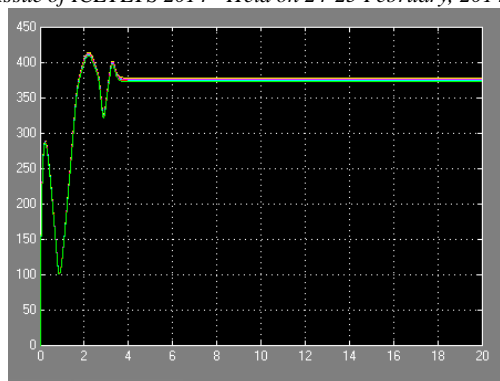

Figure 5-3: Real power versus time

VI. Conclusion

In this paper, a Distributed PFC (DPFC) concept is proposed based on the conventional UPFC application. A control strategy is proposed, simulated, and implemented on a scaled test bed. To address those problems inherent in the CUPFC, this paper comes up with a distributed PFC concept. In the proposed DPFC scheme, the function of the CUPFC is realized by more than one smaller-sized UPFC units. The injected voltage to control the power flow in the transmission line is produced, in a coordinated manner, by those series devices of the DPFC. The shunt device in every DPFC unit maintains the DC link voltage. By doing so, the real power, which is exchanged between the series devices and the voltage buses is provided or absorbed by the shunt devices. At the same time, the shunt devices realize the functionality of their counterpart in CUPFC application, which is to provide or absorb reactive power from the line. In this paper, the series injected voltage is obtained by producing voltages with equal magnitude and phase angle in all DPFC units operating on the line. The provided or absorbed reactive power is shared among shunt devices of the DPFC units equally. In such an arrangement, it is believed that the load is distributed equally among those distributed devices.

This scheme has the following advantages:

- (1) Every DPFC unit provides part of the functionality of the UPFC. In a failure scenario, only part, or even fraction if the number of the installed unit is large, of the capacity will be lost. Which increase the overall reliability of the whole system.
- (2) The power rating of each unit is distributed equally. So that, the design of the DPFC unit can be standardized. The manufacturing process can be automated on assembly lines to take advantage of the modernized manufacturing industry capability. In this way, the cost of the UPFC should be decreased dramatically. At the same time, the heat dissipation burden can be alleviated by distributing power load equally.
- (3) Lower power rating decreases the size and weight of the DPFC unit, which facilitate the installation of the devices. The footprint of the devices can be minimized

or even eliminated. Equally distribution of power rating also standardizes the installation equipment and procedure.

VII. Future Research

The main focus of the paper is the steady-state operation of the DPFC system. In future research, transient performance of the DPFC system should be investigated. The flexibility of the DPFC needs to be further studied, especially the ability to maintain voltage profile in different buses along the transmission line.

In this paper, only the sending-bus voltage control is implemented. If the command is to maintain the receiving end bus voltage, or even buses between sending-end and receiving-end bus, the ability of the DPFC system to realize the control command needs to be addressed in the future.

References

1. Vernon L. Smith, "Regulatory Reform in the Electric Power Industry, Regulation, Vol. 19, No. 1, 1996.
2. Peter M. VanDoren, "The deregulation of the electricity industry: A prime", CATO Policy Analysis, no.320, October 6, 1998.
3. U.S. Federal Energy Regulatory Commission 1995, "Promoting wholesale competition through open access non-discriminatory transmission services by public utilities", Docket RM95-8-000, Washington, DC, March 29.
4. U.S.-Canada power system outage task force, "Final report on the August 14, 2003, blackout in the United States and Canada: causes and recommendations", April 2004, U.S. department of energy, Washington, D.C.
5. N. G. Hingorani and L. Gyugyi, "Understanding FACTS, Concepts and Technology of Flexible AC Transmission Systems," Institute of Electrical and Electronics Engineers, New York, 2000.
6. S. A. Nasar, F.C. Trutt, "Electric power systems", CRC press, Boca Raton, 1998.
7. S. Matsushita, K. Yukita, Y. Goto, K. Ichyanagi, H. Aoki, Y. Mizutani, "Automatic generation control using GA considering distributed generation", IEEE Transmission and distribution conference and exhibition 2002: Asia Pacific, Vol. 3, Oct. 6-10, 2002, pp1579-1583.
8. Hossein Shayeghi, Heidar Ali Shayanfar, "Automatic generation control of interconnected power system using ANN technique based on μ -synthesis", Journal of electrical engineering, Vol. 55, No. 11-12, 2004, pp306–313.
9. Y. L. Karnavas, D. P. Papadopoulos, "Excitation control of a synchronous machine using polynomial neural networks", Journal of electrical engineering, Vol. 55, No. 7-8, 2004, pp169-179.

10. D. P. Papadopoulos “Excitation control of turbogenerators with output feedback”, International Journal of Electrical Power & energy systems 8, 1986, pp176-181.
11. F.Q. Yousef-Zai and D. O’Kelly, “Solid-state on-load transformer tap changer”, IEE Proceedings on Electric Power Applications, Vol. 143, Issue 6, November 1996, pp481-491.
12. W. Seitlinger, “Phase shifting transformers”, VA TECH Transmission & Distribution, 2001.
13. R.M. Mathur and R.K. Varma, “Thyristor-based FACTS controllers for electrical transmission systems”, IEEE Press, 2002.
14. J.D. Ainsworth, M. Davies, P.J. Fitz, K.E. Owen, and D.R. Trainer, “A static VAR compensator based on single-phase chain circuit converters”, IEE Proc. Gen. Trans. and Dist., Vol.145, No.4, July 1998.
15. C.A. Canizares, “Analysis of SVC and TCSC in voltage collapse”, IEEE PES 1998 summer meeting, San Diego, CA, July 1998.
16. C.A. Gama, E.H. Ellery, D.C.B. Azvedo, and J.R.R. Ponte, “Static VAR compensators (SVC) versus synchronous condenser (SC) for inverter stations compensation – technical and economical aspects in electronorte studies”, CIGRE Group 14 paper, 1992, pp14-103.
17. A. Edris, R. Adapa, M.H. Baker, L. Bohmann, K. Clark, K. Habashi, L. Gyugui, J. Lemay, A.S. Mehraban, A.K. Meyers, J. Reeve, F. Sener, D.R. Torgerson, and R.R. Wood, “Proposed terms and definitions for flexible AC transmission system (FACTS)”, IEEE Trans on power delivery, Vol.12, No.4, October 1997, pp.1848-1853.
18. H.L. Robert and R. Wang, “The impact of generation mix on placement of static VAR generators”, IEEE PSerc, May 21, 1999.
19. M. Carlos, J. Dixon, L. Moran, “Binary controlled static VAR compensator, based on electronically switched capacitors”, IEEE PESC’98, 1998, pp1392-1396.
20. L. Gyugyi, “Power electronics in electric utilities: static VAR compensators”, Proceedings of the IEEE, Volume 76, Issue 4, April 1988, pp483 – 494.
21. E.W. Kimbark, “Improvement of system stability by switched series capacitors”, IEEE Transactions on power apparatus and systems, vol. 85, February 1966, pp. 180-188.
22. J.J. Vithyathil, C. W. Taylor, M. Klinger, and W.A. Mittelstadt, “Case studies of conventional and novel methods of reactive power control on AC transmission system”, CIGRE paper 38-02, Paris, 1988.
23. E.V. Larsen, K. Clark, S.A. Miske Jr., and J. Urbanek, “Characteristics and rating considerations of thyristor-controller series compensation”, IEEE Transactions on power delivery, Vol. 9, No. 2, April 1994.
24. J. Zhang, G. Dai, G. Xiao, J. Zhao, H. Zhang, and S. wang, “Design of the control system for thyristor switched capacitor devices”, Transmission and distribution conference and exposition, IEEE PES Vol2, 7-12 Sept. 2003 pp606 – 610.
25. L.A.S. Pilotto, A.R. Carvalho, A. Bianco, W.F. Long, F.L. Alvarado, C.L. DeMarco, and A. Edris, “The impact of different TCSC control methodologies on the subsynchronous resonance problem”, Proceedings of EPRI conference on FACTS, Washington, DC, April 1996.
26. R.J. Piwko, C.A. Wegner, B.L. Damsky, B.C. Furumasu, and J.D. Eden, “The Slatt thyristor-controlled series capacitor project – design, installation, commissioning, and system testing”, CIGRE paper, Paris, 1994, pp14-104.
27. C.J. Hatziaodoniou and A.T. Funk, “Development of a control scheme for series-connected solid-state synchronous voltage source”, IEEE transactions on power delivery, Vol. 11, No.2, April 1996, pp.1138-1144.
28. S. Nyati, C.A. Wegner, R.W. Delmerico, R.J. Piwko, D.H. Baker, A. Edris, “Effectiveness of thyristor controlled series capacitor in enhancing power system dynamics: an analog simulator study”, IEEE Transactions on Power Delivery, Vol.9, No.2, April 1994, pp1018 – 1027.
29. S. Subhash, A. K. Tripathy, K. R. Padiyar, S. Nayyar, M. Kumar, P. J. Thakkar and K. K. Arya, “SSR study for the thyristor controlled series compensation application on the Kanpur-Ballabgarh 400kV line in India”, International conference on power systems transients (IPST’05), Paper No. IPST05 - 043, Montreal, Canada, June 19-23, 2005.
30. L. Ippolito and P. Siano, “Selection of optimal number and location of thyristor-controlled phase shifters using genetic based algorithms”, IEEE Proceedings on generation, transmission and distribution, Vol.151, No. 5, September 2004, pp.630-637.

AUTHOR’S BIOGRAPHY

¹**V.Anwasha Kumar**, Assistant Professor JInstitute of Information Technology- Hyderabad. M.Tech from K L University, Vaddeswaram, Guntur. He has completed his B.Tech from JNTU Hyderabad. He has published 4 conference papers and 4 International journals. His Area of interest is Power semiconductor drives and Artificial Intelligence, FACTS, and special machines. He is a member of IEEE, ISTE, IACSIT. IAENG.



²**Dr.G. MadhusudhanaRao**, Professor of the Department in EEE Department of TKR College of Engineering and Technology and Science. He received his Ph.D&M.Tech from JNT University Hyderabad. He has published more than 18 research papers in International Journals and 30 International conference/national conference papers. He has more than 15 years of teaching experience. He is a member of IEEE, ISTE, IACSIT etc., He is acting as reviewer for many journal like Industrial Electronics (IEEE). His Area of Interest is Power electronics and Drives, Artificial Intelligence and Expert systems.



³**Dr.B.V.Sanker Ram** did his B.E OU. Obtained M.Tech OU and Ph.D in 2003 from JNTU. He has 70 technical papers to his credit in various international and national journals and conferences. He has guided 12 research scholars for Ph.D and 6 Candidates are still pursuing their research. His areas of interest include FACTS, Power Electronic Applications to Power Systems, Power Systems Reliability.He has more than 22 years of teaching experience. He is a member of IEEE, ISTE, IACSIT etc., He is acting as reviewer for many journal like Industrial Electronics (IEEE).

